

December 2012

B 25361

CAN Newsletter

Hardware + Software + Tools + Engineering



*Proof your CANopen products –
conformance and interoperability*

*Easy access to
CAN network analysis*

*Isobus testing with implement
and remaining bus simulation*

Testing

www.can-newsletter.org



Solutions for open networks from one source

Open CAN-based protocols are the basis of networking in commercial vehicles, avionics and industrial control technology. Vector supports you in all development phases of these systems:

- > Systematic network design with CANoe, ProCANopen and CANeds
- > Successful implementation with source code for CANopen, J1939 and more
- > Efficient configuration, test and extensive analysis with ProCANopen, CANoe and CANalyzer

Multifaceted trainings and individual consulting complete our extensive offerings.

Thanks to the close interlocking of the Vector tools and the competent support, you will increase the efficiency of your entire development process from design to testing.

- ▶ **Further information, application notes and demos:**
www.vector.com/opennetworks

AFDX® is an Airbus' registered trademark

Proof your CANopen products – conformance and interoperability

Holger Zeltwanger

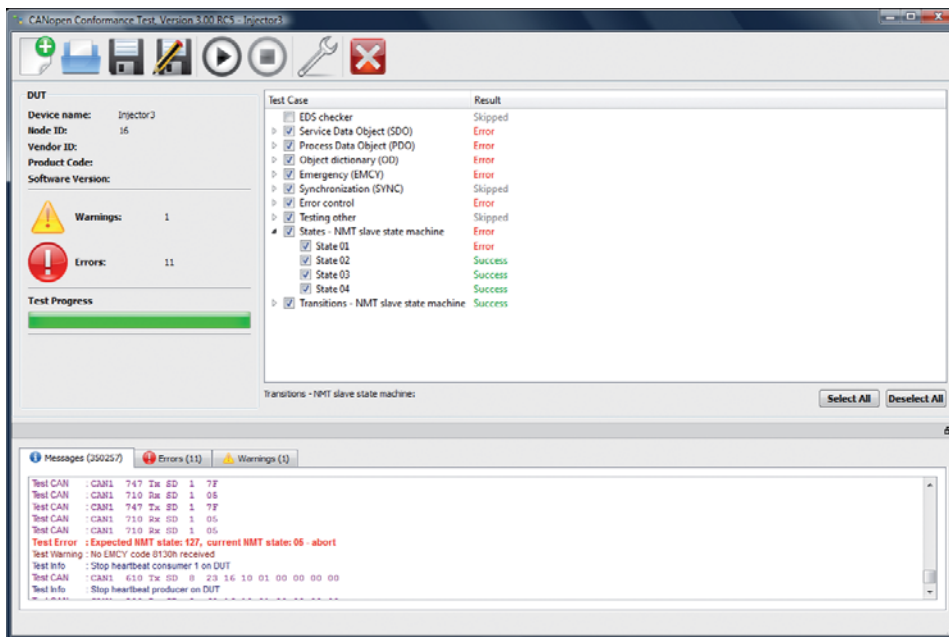


Figure 1: Current CANopen Conformance Test (CCT) tool

The bell rings. The apprentice opens the door of the CiA office. The postman hands-over a package, which Oskar Kaplun, one of CiA's engineers performing the conformance tests, already expects. He opens the package. It contains the CANopen device to be tested, and the related Electronic Data Sheet (EDS) and the handbook, of course. He switches on

the PC, which runs the CANopen Conformance Testing (CCT) software. The engineer working with CiA since three years powers the device, sets the

CAN bit-rates of the tool and the devices to 250 kbit/s, and connects the bus-lines. This is the maximum bit-rate, which this device-under-test (DUT) supports.

“In my 10 years experience, about 50 per cent of the devices submitted for CANopen conformance testing pass the tests without serious problems, the others require a review of the software and a second test session or more.”

Thilo Schumann

After reading-in the EDS, he checks its conformity by means of the free-of-charge EDS checker maintained by Vector Informatik (Germany). After some mi-

nor corrections of the EDS, he links it to the test tool and starts the test procedure. Before he has set the node-ID to a random value. The conformance test runs more or less automatically. He goes back to his desk continuing editing CANopen profile specifications and answering technical question by email.

Conformance testing is like spell and grammar checking in Word.

The CCT software tool generates test pattern, sends them via the bus to the DUT, and evaluates the responded CAN frames with expected test results as specified

Author

Holger Zeltwanger
CAN in Automation e. V.
Managing Director
headquarters@can-cia.org

Definitions

- ◆ **Compatibility:**
Capability to exist or perform in harmonious, agreeable, or congenial combination with others.
- ◆ **Conformance:**
Compliance in actions, behavior, etc., with certain accepted standards or specifications.
- ◆ **Compliance:**
A disposition or tendency to yield to the will of others.

- ◆ **Interoperability:**
The ability of systems or units to provide services to and accept services from other systems or units, in order to operate effectively together.
- ◆ **Interchangeability:**
The ability to be replaced by another entity without additional configuration effort.

Links

www.can-cia.org
www.ixxat.com
www.kuebler.com
www.maxonmotor.com
www.microcontrol.net
www.ni.com
www.port.de
www.posital.com
www.schneider-electric.com
www.vector.com

Conformance test limits

The CANopen conformance test plan covers just the CiA 301 functionality. Additional tests for CiA 302 functions need to be specified. Test plans for the CANopen profiles have been partly developed, but they have not been implemented in the current CANopen Conformance Test (CCT) tool. This will be done by plug-ins on request of CiA's Special Interest Groups. However, such profile tests require an upper tester, which is device-dependent. This upper tester needs communication to existing lower tester, which is the CCT software tool running on a Windows PC.

Interoperability test limits

The current CANopen interoperability test stand in the CiA office is based on a mid-range PLC. It is intended to use also other host controllers with NMT master functionality. Most of the currently performed test procedures derive from Schneider Electric's internal test experiences gained in its own test center in the last couple of years. CANopen devices implementing an application profile could not be tested in this system. For them plug-fests or demonstrators only integrating devices compliant to the same application profile are the right choice to test interoperability.

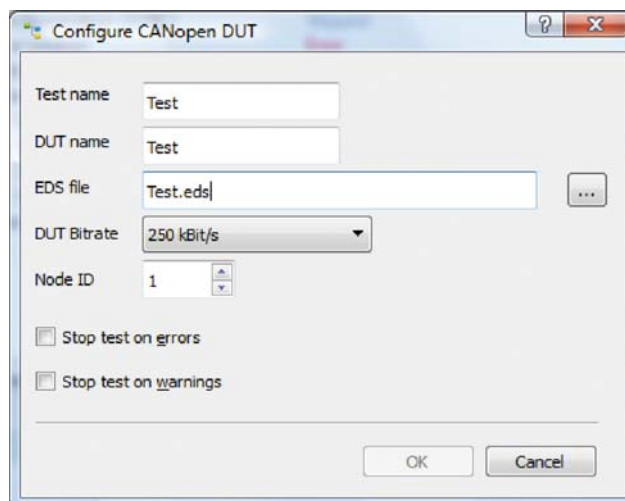


Figure 2: Test start window of the current CCT tool

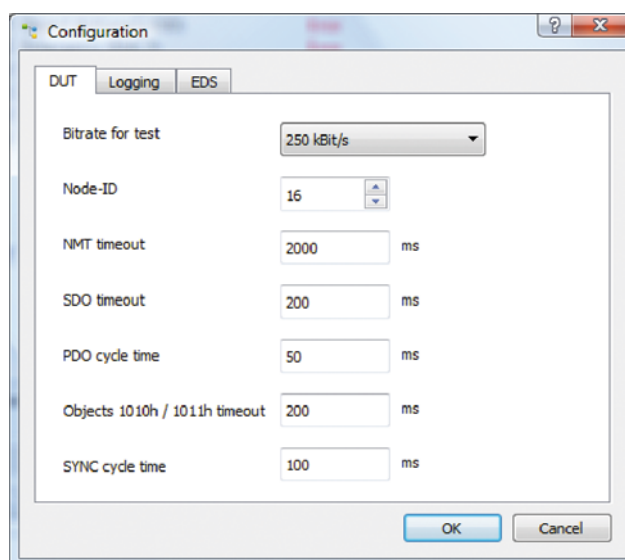


Figure 3: Configuration of communication parameters with the current CCT tool

in the CANopen conformance test plan specification. The test pattern depends on the CANopen functionality of the DUT as described in its EDS. This means, the DUT is tested against its own description. If the received responses are not conformant to the CiA 301 test specification, the CCT software generates a failure report or in some cases just a warning.

From time to time, Oskar Kaplun or another CiA engineer goes into the test room to look on the test progress. This device is a good one, passing most of the test successfully. Just a few warnings and one

failure happened. With the test report he goes to Thilo Schumann responsible for CANopen conformance testing services in order to discuss the test result. The failure is not a failure: It is

“For interoperability testing we organize plug-fests, we provide a ‘golden’ CANopen system, and we build demonstrators for dedicated CANopen application profiles.”

Reiner Zitzmann

caused by a known error in the test tool. The warnings are also no failures: They are just hints for the device designer that the tested unit could not be used for all applications. Normally, this should be mentioned in the

handbook as application limits.

Conformance testing is like spell and grammar checking. This means, even if the device has passed the conformance testing successfully, this doesn't guarantee interoperability with other CANopen devices. Of course, CANopen conformance tested devices have a higher probability to be interoperable compared with such that have not passed the test. However, like in human communication, you can respect grammar rules and spelling, but your discussion partner misinterprets or misunderstands you. In particular, the conversation between males and females is sometimes behaving like this. On the other hand, if two dialog partners violate the grammar rule in the same manner, they will understand each other. They are interoperable. If in CANopen you violate the rule of the length of an SDO (service data object) message (it has to be 8 byte), and the involved CANopen devices accept that, they are interoperable but not conformant to CiA 301.

CiA members (ESD, Micro Control, Port, and Sandvik) have developed jointly the new CANopen Conformance Test software. It overcomes some problems of the predecessor, which has been pre-developed by National Instruments (NI) end of the last century. A couple of years ago, NI has handed over it to CiA office for further maintenance and further development. The new CANopen

Conformance Test software uses the same low-level software interface to the CAN hardware – the COTI interface. Several vendors of PC/CAN interfaces support this interface (you find a list of tested



CAN



EtherCAT®



Janz Tec AG – 30 years of experience in industrial computer systems

emPC



emVIEW



CAN Interface



Janz Tec AG, previously known as Janz Automationssysteme AG, has been one of the leading manufacturers of electronic assemblies and complete industrial computer systems since 1982. The future-oriented and extremely reliable technology from Paderborn is in demand the world over: well-known companies from the mechanical and facility engineering, power and energy, transport and traffic, the medical technology and automotive sectors are all part of our satisfied customer base.

Good communication is very important nowadays – not just in real life, but also in machines, plant and complex industrial applications from a wide range of industries. This applies especially if error-free trans-

mission of data is required due to more and more compact construction and the necessity for more performance in the case of distributed systems. For this reason, Janz Tec AG also places great value on innovative and sophisticated technology in the Industrial Communication business sector. The InCom products developed in-house enable the control systems for your machines, plant and systems to be kept at the highest level.

Did you ever think that good communication can be so simple? You can find out more details about the services offered by Janz Tec AG in the Industrial Communication sector during a personal consultation.

janztec
Industrial Computing Architects

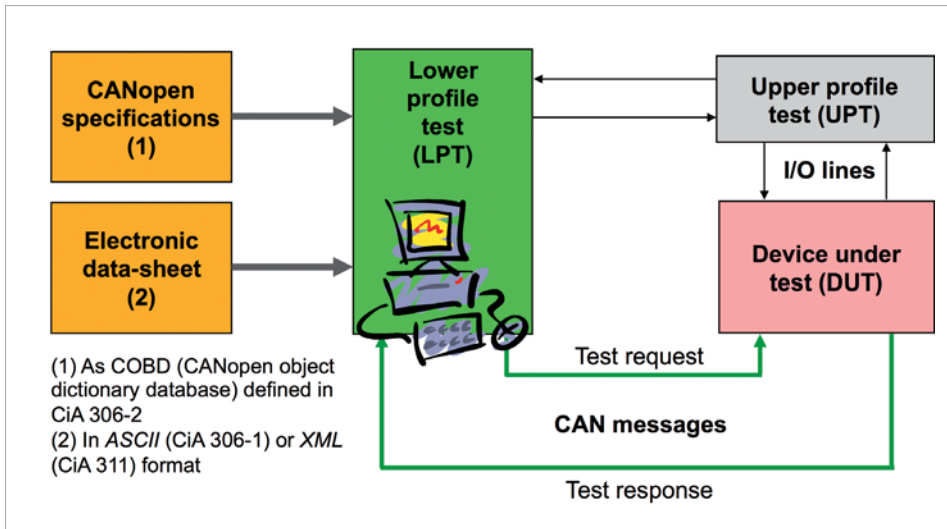


Figure 4: Lower profile test principle

products on CiA's website). It is intended that CiA members get the CCT software tool on request free-of-charge. Non-members may buy it from CiA. The conformance testing of devices by CiA is still a service to

be paid. Of course, device designers may test the devices by themselves, which is so-to-say a self-certification. However, testing what you have developed by your own is like checking the text you have written your-

self. You will not detect all your spelling and grammar errors – you will read over some of them. The same may happen when you test your device by yourself. This is why an increasing number of companies sub-

mit their CANopen devices for independent conformance certification to CiA. It is not that expensive (for details see CiA's website).

As mentioned above, conformance testing doesn't guarantee interoperability to other devices. If one device produces EMCY (emergency) messages and the other can't consume them, they are not interoperable. In order to examine interoperability, CiA offers since some years the so-called plug-fests. There, CiA members connect their CANopen products and prove if they can communicate. This includes the testing of physical transmission limits, exchanging SDOs and Heartbeats as well as interpreting the exchanged PDOs (process data objects). The CANopen SIGs (Special

The 'golden' CANopen network

At the CiA booth on SPS/IPC/Drives 2012 exhibition in Nuremberg (Germany), the interoperability test system will be shown. In contrast to the CANopen conformance test, the aim of the interoperability test is to assure that the CANopen device is capable of interacting with a variety of other CANopen devices (made by different manufacturers), all integrated and communicating with one another in one network. The test stand was built up with CANopen devices provided by CiA member companies such as Fritz Kübler, Ixxat Automation, Maxon Precision Motors, Micro Control, Port as well as Posital, Schneider Electric Automation and Vector Informatik.

The heart of the test stand is the mid-range Modicon M340 programmable logic controller by Schneider Electric. Further CANopen devices are I/O modules, encoders, drives, temperature sensors, and so on. The network is dimensioned to run all recommended CANopen bit-rates (1000, 800, 500, 250, 125, 50, and 20 kbit/s).

The device under test (DUT) is connected with a stub cable to

the network and is afterwards integrated to the PLC's network setup by an engineer of CiA. The configuration as such, depends on a variety of possible test sequences that can be chosen. The test sequences include stress tests affecting the physical layer as well as a variety of other tests that aim on checking if the DUT's CANopen functionality behaves properly.

When it comes to tests affecting the physical layer, CiA engineers trigger various emulations of line failures, short circuits as well as interruptions to check how the DUT responds. However, the main focus of the interoperability test lies on checking if the implemented CANopen functions work properly during interaction with other devices on the network. CiA staff worked out a series of test sequences including basic tests, checking the heartbeat functionality, up to advanced device tests in which node-ID or the bit-rate are changed with the usage of the LSS (layer setting services). One of the important basic test issues lies in the testing of the RPDOs (receive process data objects) and/or TPDOs

(transmit process data objects) behavior. CiA's engineers take a thorough look on the range of possibilities that can be used when working with RPDOs and/or TPDOs, for example, how the possible TPDO scheduling modes work. This does not only mean configuring a TPDO with the PLC and checking, if an event or the event-timer causes the PDO transmission. Also, cyclic or acyclic transmission is checked as well as the SYNC counter (if implemented).

To make the variety of test sequences practically relevant, most of the tests are fulfilled with different busloads. Different scenarios are distinguished in case usage of different busloads – a low, an average and a high busload. With the resulting information, device manufacturers are able to get a statement at what busload their devices are still able to communicate correctly.

The service of interoperability testing aims to really see, where the problems are when devices are integrated in networks in the field. Often it is not enough to be compliant to the CiA 301 specification.

Mark Buchert

ifm electronic



7844 x
passion!



A mobile dialogue: Robust and simple to operate

One of 7844 products we developed for you with passion: Dialogue module PDM360 NG for mobile vehicles.

The powerful process and dialogue unit of the latest generation has a scratch-resistant high-resolution 7" TFT colour display. 9 backlit function keys with tactile feedback guarantee intuitive operation in the field.

Its robust diecast housing with protection rating IP 67 ensures the highest reliability for mounting inside or outside the cabin. It is easy to program and allows immediate fast and flexible use.

ifm electronic – close to you!

www.ifm.com/gb/mobile

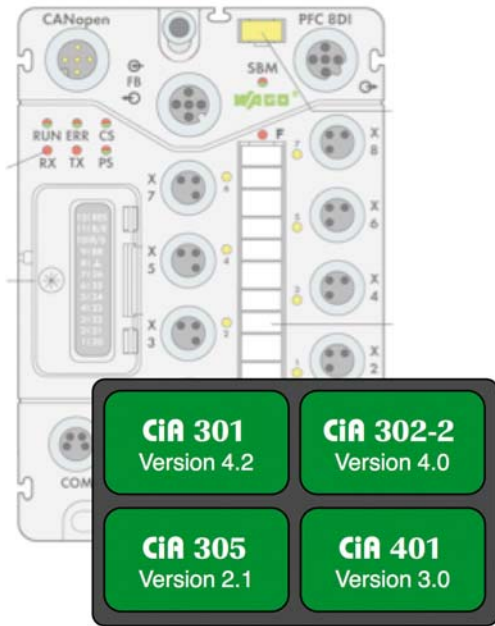


Figure 5: Example CiA-profile compliance label, which could be printed on the product

Interest Groups) Lift control systems and Sub-sea instruments do that regularly. The SIG Lift has also initiated the production of demonstrators. These are real CANopen Lift control systems based on CiA 417 compliant devices. Today there are three CANopen

Lift systems realized, which are shown on fairs and conferences. Already in 2008, CiA members have exhibited a CleANopen (CiA 422) demonstrator comprising devices for refuse collecting vehicles from different manufacturers.

Since summer of this year, CiA has also setup a 'golden' CANopen network. It comprises a PLC with NMT master functionality and several CANopen NMT slave devices. This CANopen system is used to prove the interoperability of any submitted device. You may send your device to CiA. Oskar Kaplun or Reiner Zitzmann will integrate this device into the system and perform functional as well as stress tests.

In order to support CANopen system designers, it would be helpful, when CANopen device manufacturers would provide a compliance statement. That is that you reference the version of the CiA specifications, which have been implemented. For example: CiA 301 version 4.2, CiA 302-2 version 4.0, CiA 305 version 1.0, CiA 406 version 2.0, and so on. It would also be nice to have a standardized CANopen compliance label, which could be printed on the product, if space is available.

If you like to substitute a CANopen device by another CANopen device from a different manufacturer, it may happen that there is no product with the same functionality available on the market. Of course, in some cases it is possible to configure the other device to integrate it into your system or you can adjust your application software. This is because most of the CiA specifications provide many optional functions. To make it easier for system designers, CiA started to reduce the possible number of variants by means of specifying several device classes

for each profile. The profiles supporting such classes include CiA 425-2 (contrast media injectors) and CiA 851 (truck-mounted cranes). Also CiA 402 (electrical drives and motion controllers) specifies implicitly some device classes.

Oskar Kaplun finishes the paperwork for the performed CANopen conformance test. He prints the test results, adds his test report including hints how to improve the device, and provides all necessary information for CiA's book keeping department in order to write the invoice. The apprentice packs the tested device and the necessary custom declaration, and calls the transport agency. The next device for CANopen conformance testing may arrive. Maybe it is yours. ◀

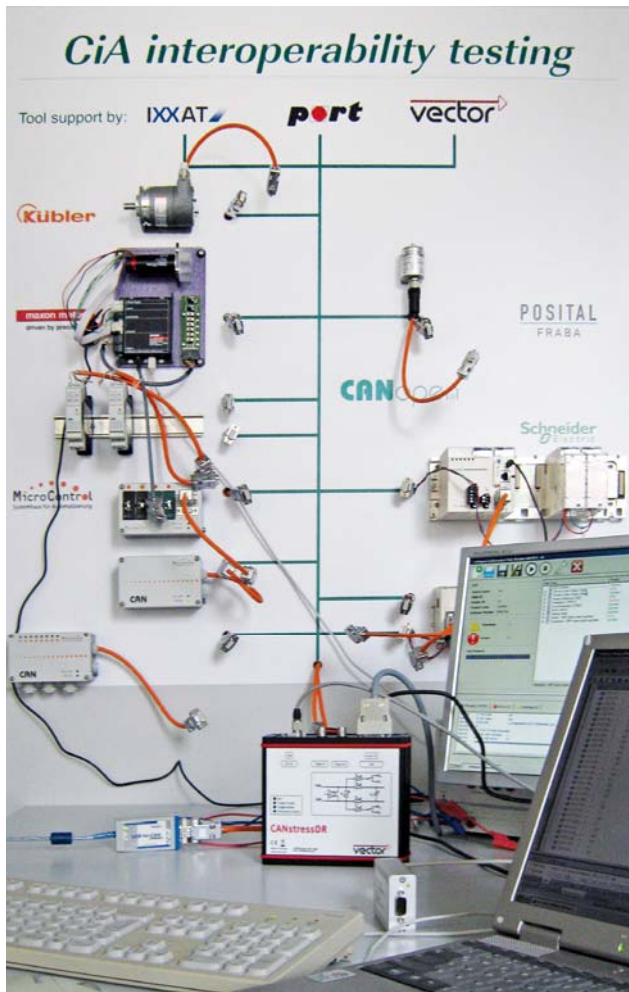


Figure 6: CiA's interoperability testing system

You CAN get it...

Hardware & software for CAN bus applications...



LINUX device driver available



PCAN-USB Pro

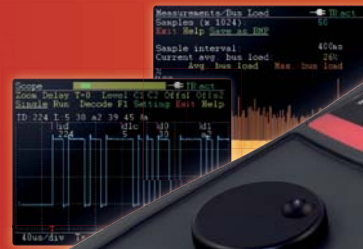
High-speed USB 2.0 interface with galvanic isolation for connecting up to 2 CAN and 2 LIN busses.



NEW

PCAN-PC/104-Plus Quad

Four-channel CAN interface with galvanic isolation for PC/104-Plus systems.



NEW

CAN bus diagnostics with trace function

PCAN-Diag 2

PCAN-Diag 2 is a handheld CAN bus diagnostics unit. The new model offers enhanced functionality:

- ___ Clear CAN traffic representation in lists, configurable symbolic representation of received messages
- ___ Transmission of individual CAN frames or CAN frame lists
- ___ Built-in 2-channel oscilloscope for detailed analysis of the differential CAN signal or an optional external signal, triggering by CAN IDs or other events
- ___ Bit rate detection, bus load and termination measurement
- ___ Windows® software for easy device configuration and transmit list definition, upload via USB connection
- ___ Storage of diagnostic results (CSV, BMP) on an internal 1 GB mass storage USB device



NEW

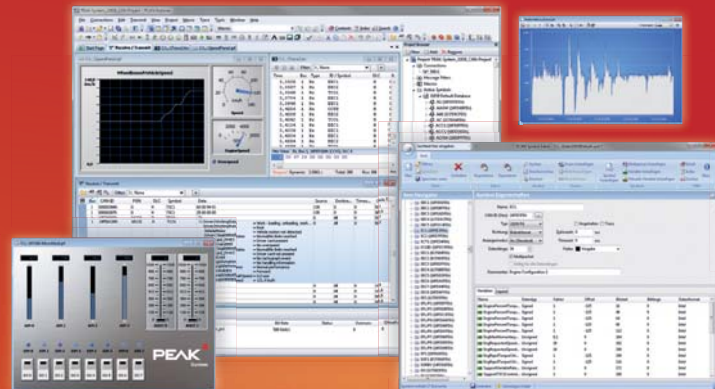
PCAN-PCI Express

CAN interface for PCI Express slots. 1, 2, and 4-channel versions with galvanic isolation available.



PCAN-Repeater

Repeater for the galvanic isolation of 2 CAN bus segments, bus status display, switchable termination.



PCAN-Explorer 5

The universal tool for developing and monitoring CAN networks.

- ___ Extensive user interface improvements: File management via projects, configuration of all elements with the property editor, and window arrangement using tabs
- ___ Simultaneous connections with multiple networks / CAN interfaces of the same hardware type
- ___ Configurable symbolic message representation
- ___ Data logging with tracers and the 4-channel Line Writer
- ___ VBScript interface for the creation of macros
- ___ Functionality upgrades with add-ins (e.g. **Plotter**, **J1939**, **CANdb Import**, or **Instruments Panel** add-in)
- ___ User interface language in English or German



NEW

PCAN-miniPCIe

CAN interface for PCI Express Mini slots. Single- or dual-channel versions with isolation available.



E1

PCAN-GPRS Link

Development platform with CAN, GPS, and GPRS. Interpretation of OBD-2-, FMS-, DTCO-, & CiA® 447.



NEW

PCAN-RS-232

Programmable converter for RS-232 to CAN with library and programming examples.

Take a look at our website for the international sales partners

www.peak-system.com

Otto-Roehm-Str. 69, 64293 Darmstadt, Germany
Phone: + 49 6151 8173-20 – Fax: + 49 6151 8173-29 – E-mail: info@peak-system.com

PEAK
System



Cover story

Proof your CANopen conformance and interoperability 3

According to experience of CiA engineers, about 50 % of the devices submitted for CANopen conformance testing pass the tests without serious problems, the others require a review of the software and a second test session or more.

Imprint

Publisher

CAN in Automation GmbH
Kontumazgarten 3
DE-90429 Nuremberg

publications@can-cia.org
www.can-cia.org
www.can-newsletter.org

Tel.: +49-911-928819-0
Fax: +49-911-928819-79

CEO Holger Zeltwanger
AG Nürnberg 24338

Printed in Germany
Hardcopies: 3000
Soft copies: 2500

Editor-in-chief
Holger Zeltwanger

Editor
Olga Fischer

Layout
Bettina Seuffert-Bischoff

Advertising manager
Gisela Scheib

Distribution manager
Julia Adolf

© Copyright
CAN in Automation GmbH



Testing

Easy access to CAN network analysis 12

Isobus testing with implement and remaining bus simulation 38

Hardware

CAN communication with fiber optics 14

Modular train communication system 22

Controller for mobile machinery 42

CANopen and J1939 sensors for agricultural technology 44

Engineering

Accelerated transfer of CANopen projects into assembly and service 16

Conference on electronics in mobile machinery 36

Network design

Challenges for future vehicle networks using different voltage domains with regard to EMC 24

Energy saving in automotive electronics architectures 46

Understanding and using the CAN protocol 58

Current information and testing possibilities for CAN FD



On Thursday, October 18, Bosch and CiA have jointly organized the CAN FD (CAN with flexible data-rate) Tech Day in Detroit (USA). More than 100 attendees listened to the presentations by OEMs, chipmakers, and tool providers. Etas and Vector presented their plans for CAN FD tools. Etas will provide a CAN FD option for its ES890 bus interface module and is preparing its ES59X series of ECUs as well as its ES9XX family of modular rapid prototyping hardware for CAN FD communication. Also the open-source Busmaster analyzing tool is ready to support CAN FD communication. Due to the fact that Vector's DBC database format supports 64-byte entries, CAN FD messages can be described using this industry standard. The German tool maker will support CAN FD in its CANoe and CANalyzer tools by end of 2012. The initial support is restricted to 8-byte data fields, 64-byte support will follow.

More first-hand information on CAN FD you find on www.can-newsletter.org

The WAGO I/O CANopen[®] Product Range Keeps On Growing!

AUTOMATION

CANopen[®]



NEW! IP67 Protected CANopen[®] Coupler

- Eight integrated digital inputs
- Extendable via system bus
- Maximum extension of 500 meters
- Expansion with up to 64 I/O modules
- High-performance, configurable I/O modules
- High diagnostic coverage
- Temperature range from -25 °C to +60 °C
- DS 301 communication profile
- DS 402 I/O profile
- Also available as 767-2501 Programmable Coupler



750-337



750-338



750-347



750-348



767-1501
767-2501



750-837

WAGO Kontakttechnik GmbH & Co. KG
Phone: +49/571/887-0
Fax: +49/571/887-169

www.wago.com

WAGO[®]
INNOVATIVE CONNECTIONS

Easy access to CAN network analysis

Jochen Neuffer



Author

Jochen Neuffer

Product Management

Engineer

Vector Informatik GmbH

Tools for Network and

Distributed Systems

Ingersheimer Str. 24

DE-70499 Stuttgart

Tel.: +49-711-80670-4808

Fax: +49-711-80670-584808

jochen.neuffer@vector.com

Link

www.vector.com

Changing requirements are continually in flux when it comes to networking ECUs (electronic control units). The general trend for tasks is becoming increasingly more complex, and so they require even more complex tools. However, there are often simple tasks whose quick handling is actually hindered by this complexity when the user is confronted with a multitude of features. For such tasks, the user wants an easy-to-operate tool. However, if the task requires it, the user also wants to be able to access an extensive set of features.

These conflicting interests occur in typical tasks such as network monitoring, stimulation or data logging. In the case of monitoring, for example, different perspectives are often of interest in observing the data

traffic on the network. Here, the Trace function shows the time sequence of all network events. It is also possible to graphically display individual parameters. Moreover, the user typically wants an overview of the network statistics. In stimulation, on the other hand, specific messages need to be sent on the network either spontaneously or periodically. And of course data needs to be logged for later off-line analysis.

These three core tasks are the domains of CANalyzer Beginner, a special execution mode of CANalyzer from Vector Informatik. The mode that focuses on these core tasks is easy to operate even for new users. The individual task areas may be combined, and each may be added or removed whenever the user wishes. The full range of CANalyzer

er features is at first not visible to the user, but it can be called up at any time.

CANalyzer Beginner can be immediately used as part of any CANalyzer installation (CAN and LIN networks). This saves the user time and money, because there is no need to purchase or install a separate tool. The Beginner mode exploits the advantages of the revised window layout in CANalyzer. The individual tasks are organized on fixed desktops, which do not need to be modified, and which already contain pre-configured windows (see Figure 1). This eliminates the need for time-consuming manual configuration. Since the windows have fixed positions, it is easy to focus on the essentials. Furthermore, the windows cannot be closed, which eliminates

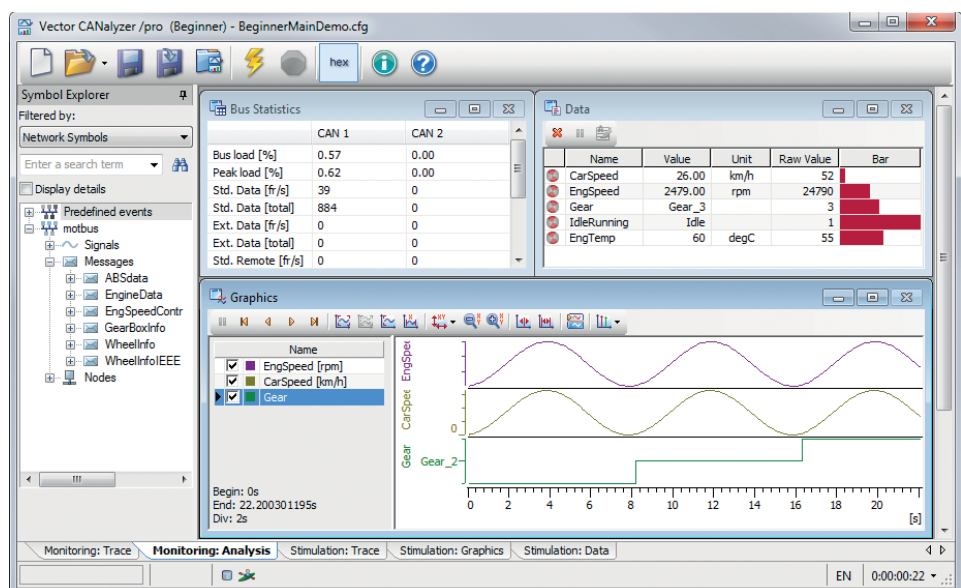


Figure 1: Desktop with fixed configuration for network monitoring task (Source: Vector Informatik)

PC Interfaces

New series for maximum flexibility

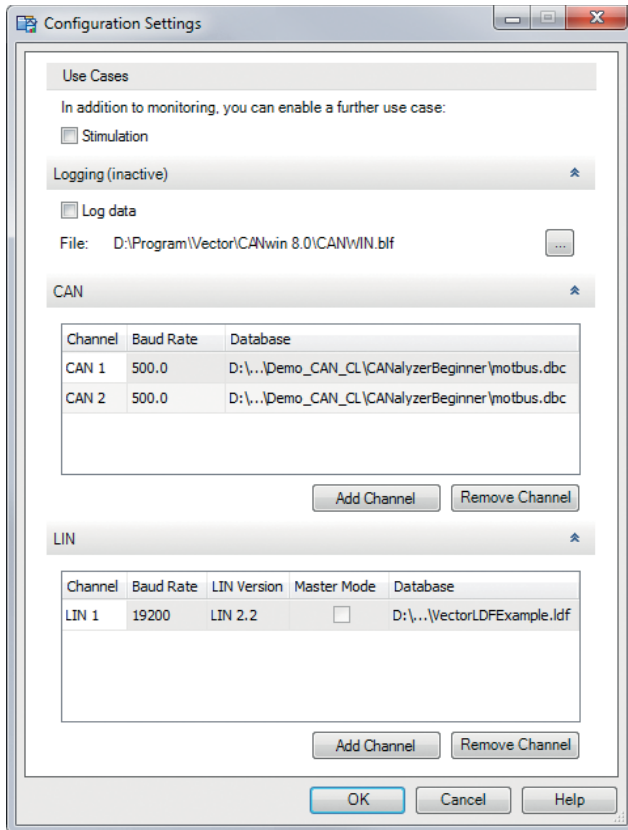


Figure 2: Creating a new configuration with CANalyzer Beginner (Source: Vector Informatik)

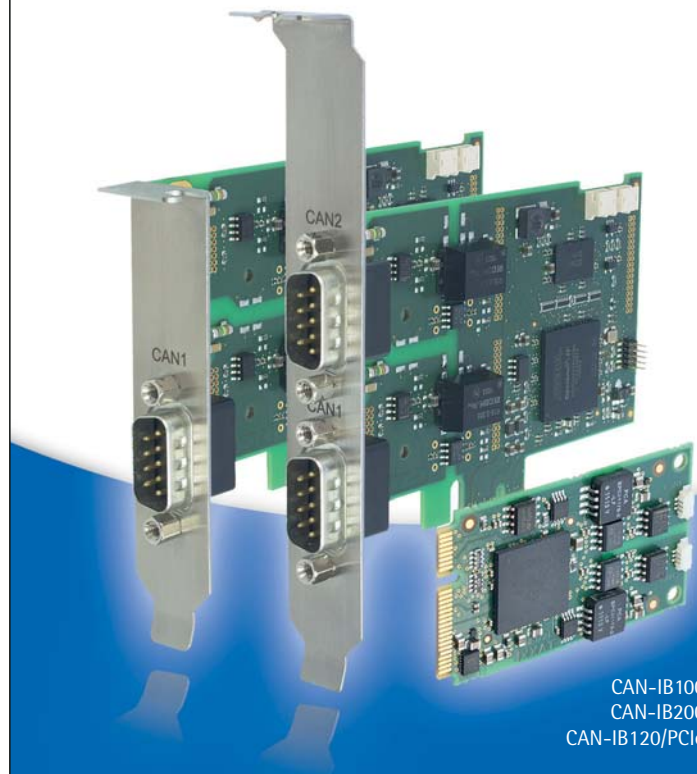
searching for inadvertently closed windows. The windows are configured by drag-and-drop operation or with the help of functions on the toolbar.

One can create his own configuration with a few mouse clicks. To do this, the user needs to add for each network a channel and a suitable network description file (DBC for CAN or LDF for LIN) to the central configuration window (see Figure 2). If applicable, the bit-rate is also configured, and the user then selects the tasks that need to be performed. During the measurement, for example, the Trace window offers many different options for filtering specific events, such as blocking and passing filters for messages or channels. Furthermore, the Trace window offers a long data history, so that long-term measurements over several days can be preserved. The Statistics window offers a detailed summary of the current situation

on the network and can prepare statistical information on the node level or the message level.

Also complex tasks may be performed. A configuration created with the Beginner mode can be loaded in its full form in CANalyzer. It is also possible to use CANalyzer to perform further off-line analysis of logged data. There is a seamless migration path from CANalyzer Beginner to CANalyzer. Configurations that have been created with CANalyzer Beginner can be loaded in CANoe as well.

Future planning for CANalyzer Beginner calls for supporting additional tasks and possibly adopting concepts into CANalyzer. ◀



CAN-IB100/PCIe
CAN-IB200/PCIe
CAN-IB120/PCIe Mini

Cost-effective and modular PCIe card series for industrial and automotive applications

Up to four CAN lines (opt. high/low speed or galv. isolation) and up to four LIN ports

Available in standard, low-profile, PCIe Mini and PCI/104 Express formats

Drivers for Windows, Linux, INtime and RTX as well as Windows monitoring tool included

NEW!



PCI/104-Express interface board with up to 4 CAN channels, low-speed CAN and LIN.

CANblue II with PC interface functionality and Windows driver, in addition to bridge and gateway operation.



NEW!

IXXAT

Your Partner for Communication

IXXAT Automation GmbH
Leibnizstr. 15 · 88250 Weingarten
Tel.: +49-(0)7 51 / 5 61 46-0
Internet: www.ixxat.de

CAN communication with fiber optics

Uwe Ackerschott

Author

Uwe Ackerschott
EKS Engel GmbH
Sales and Support
DE-57482 Wenden
Tel.: 02762 9313-85
ua@eks-engel.de

Link

www.eks-engel.de

Summary

With fiber optics the performance of CAN networks may be increased. The D-Light CAN converter systems by EKS Engel may connect two CAN nodes across distances of up to 100 km and transmit data with bit-rates of 1 Mbit/s. Apart from that, the "FiberView" system allows monitoring the fiber optic path continuously. Thus, reliability and permanent access to machines and other units is guaranteed.

Fiber optics offers a range of advantages for use in CAN networks, above all transmission across long distances, high data transmission rates and a maximum of security.

Active components for rough industrial environments are commonly offered.

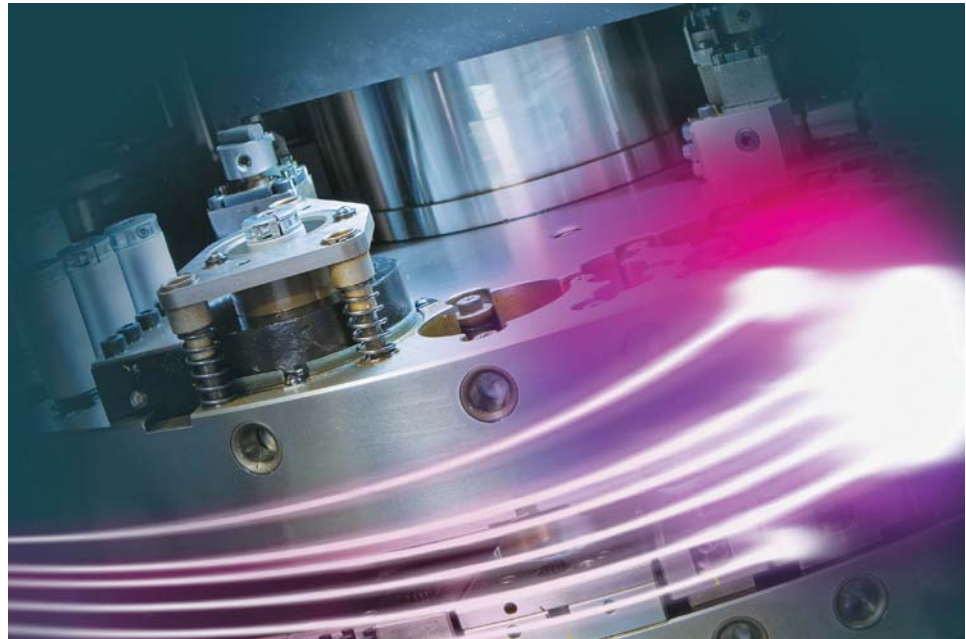


Figure 1: Punching machine using fiber optics

Since fiber optic cables consist of electric, non-conductive material, data is always transmitted by an electric insulator. This eliminates potential equalization currents that are a particular cause of concern in extensive networks. Even in case of lightning there is no risk of damage for the network devices. Compared to twisted pair cables, fiber optics needs no grounding or additional shielding. Since light is not influenced by electric or magnetic interferences, fiber optics can be installed right next to power lines or other electro-magnetic sources.

Regarding prices there is no real difference between twisted pair and fiber optic cables. Nevertheless, 1 kg of fiber optics is as powerful as 1000 kg of copper. Finally, the resource balance speaks for itself:

Copper is too valuable to install it in terms of cables. Fiber optics, however, consist of silicate, which is available almost indefinitely. This also applies to the raw material of fiber optics, which are made of plastic.

Single-mode fibers transmit data across distances of up to 100 km. For shorter distances (up to 5 km) multi-mode fibers are a cost-efficient alternative. There are, in fact, cables, which are delivered with connectors and attenuation protocol already, but this is only recommendable if the cable lines are easily accessible and not longer than 300 m because it must be possible to unroll the cable. For distances up to 50 m, POF (Polymer Optical Fiber) cables are a useful alternative. They are real plastic fibers, which can be connected without any spe-

cial tools – a sharp knife and fine-grained sandpaper are enough.

Apart from that, professionals should assemble the connectors and measure the attenuation on site afterwards. This – unlike pre-assembled versions – avoids the risk of damaging a cable during assembly and ensures that the infrastructure is working properly.

CAN transmission

D-Light CAN converters by EKS Engel change electrical CAN signals into optical signals and are suitable for point-to-point, line or redundant ring structures. Apart from multi-mode and single-mode fibers, POF fibers can be used as well. Furthermore, it is possible to have mixed optical-electrical structures. ▶

Universal Gateway Solution for CAN



Figure 2: D-Light CAN converter for changing electrical into optical signals

As the converters work on the physical layer, the systems using different protocols based on CAN (e.g. CANopen or DeviceNet) may be supported and can be cascaded optionally. It is possible to have various connector types on the device such as ST, SC, SMA or E2000. For single-mode and multi-mode fibers there is also an SC connector that supports BiDi-technology (bidirectional), i.e. a communication in two directions via a single fiber.

For the data transmission, the converters provide a budget (difference between transmission power and receiver sensitivity) that bypasses the attenuation depending on the fiber optic cable. The attenuation, however, often increases step by step due to loose connecting components, dust and dirt, light incidence, mechanical conditions or changes in network topology. Up to now this could only be recognized by complex measurements such as optical time-domain reflectometer (OTDR). "FiberView" is a monitoring system that was especially developed for this kind of task. It consists of a hardware/software combination that is integrated into the active components and monitors the budget of the fiber

optic path per port. The introduced fiber optic converters provide this monitoring system. The LEDs at the front show if the budget is OK (green), limited (yellow) or insufficient (red). If the yellow LED flashes it is just below the selected system reserve of 3 dB. Since this pre-warning level is additionally indicated via a potential-free contact it can also be evaluated in SCADA-systems. In contrast to status updates, which might often be misinterpreted, the "traffic light" principle is generally understandable. Furthermore, the yellow status allows the user to plan his action in a more foresighted way; for the attenuation is not yet too high, i.e. the fiber optic paths is still working. However, service and maintenance work should already start in order to avoid any network breakdowns. Thus "FiberView" helps increasing productivity and reducing costs. ◀



CANbridge

Easy expansion of the bus length and implementation of tree and star topologies

Connection of systems using different baud rates

Powerful filter functionality

Transparent operation, can be used with customer-specific protocols as well as with CANopen, DeviceNet, and SAE J1939

Easy adaptation of the functionality and protocol conversion via optional Application Development Kit

NEW!

Easy and fast setup using the included Windows configuration tool.



IXXAT

Your Partner for Communication

IXXAT Automation GmbH
Leibnizstr. 15 · 88250 Weingarten
Tel.: +49-(0)7 51 / 5 61 46-0
Internet: www.ixxat.de

Accelerated transfer of CANopen projects into assembly and service

Dr. Heikki Saha

Author

Dr. Heikki Saha
sahat@kotiposti.net

References

- [1] Saha H., Wikman M., Nylund P., *CANopen network design and IEC 61131-3 software design*, CAN Newsletter 3/2009, 2009, pp. 52–58
- [2] Saha H., Bäck B., *Commonality between hydraulic valves driven by general purpose CANopen I/O and hydraulic CANopen drives*, Proceedings of 13th iCC, 2012, pp. 11-1 – 11-7
- [3] Saha H., *Benefits of intelligent sensors and actuators throughout the systems life cycle*, The 12th Scandinavian International Conference on Fluid Power, May 2011, Tampere, Finland, I SBN-978-952-15-2517-9, pp. 169–181
- [4] *CANopen application layer and communication profile*, CiA 301, CAN in Automation
- [5] *CANopen additional application layer functions – Part 3: Configuration and program download*, CiA 302-3, CAN in Automation

One of the main targets in the industry is to improve operational efficiency by maximizing the re-use of components in as many positions as possible with minimum changes. Typically the target is reached by maximizing the use of nodes according to various CANopen device profiles with application-specific configurations. CANopen defines the system management process and standard design files ([1], [7]). DCF files are designed to be used as information source in configuration downloads and target format in troubleshooting. EDS files are used as templates in both use cases, describing the interface supported by each node.

Components in a distributed system always need information of their position in a target system. Information includes parameters controlling both communication and device behavior. In general, when there may be plenty of similar devices, it is impossible to fully automatically assign them with corresponding target positions without significant constraints. Therefore, the most reliable way is to download configuration node-by-node before the physical installation. It is possible to automatically determine available components, but manual assignment of target positions is required. Isolated control and configuration download applications enable trans-

ducer and actuator updates without a need for updating the application, as long as CANopen device profiles are followed.

Uniform way of working is required to enable efficient configuration management in assembly and service. Using more than one approach will multiply the number of required tools and amount of education effort required by assembly and service personnel. Moreover, if multiple approaches are used, the risk of regular problems and support requests increases.

Design requirements

CANopen project is required for each system to support efficient and managed assembly and service. It is most efficient to design systems according to the CANopen system design process resulting CANopen project for the system [7]. Main phases of the system design are definition of signal connections, parameter values and access paths [3]. If a managed process is not used, CANopen project information can also be read from validated prototype and stored as CANopen project by a system design tool. The latter approach is not recommended, because there is a significant risk for unintentionally invalid parameter values.

System design tools use EDS files as standard

input for capabilities of the nodes [1] [7]. Interfaces of the application programs can be managed as profile databases to maximize re-usability ([1], [8]). External tools can also be linked to the system design tool with corresponding entries of EDS file [9]. Complete CANopen project consists of DCF file for each node and nodelist.cpj [9] listing the DCF files of the project. In addition to the configuration management, communication database generated by system design tool can be used in diagnostics, rapid control prototyping and simulation. XDD and XDC files cannot be used, because e.g. tool integration is not currently supported [10].

Requirements for download

CANopen systems do not necessarily contain application programmable devices. The most simple control systems can be implemented with standard nodes according to the appropriate device profiles [2]. Therefore, at least configuration management with an external tool needs to be supported to enable uniform way of working with any kind of CANopen system. A clear benefit is, if the same tool can be integrated as part of control system, too. Functional safety standards expect the use of download procedure with download, ▸

store, reset and verify and an intuitive user interface to minimize the number of errors [12].

CANopen devices may have any bit-rate and node-ID by default, especially in service actions, where

spare parts may also be borrowed from other machines. To enable a uniform handling of any CANopen device, independent of the supported download method for node-ID and bit-rate, a point-to-point connec-

tion to a single device is required. Many devices support only LSS switch mode global command or changing bit-rate and node-ID via object dictionary, which cannot be used with more than one node connected.▷

Node-ID and bit-rate

There are various approaches used for setting node-ID and bit-rate to the devices. The used approach has a strong impact on the overall performance and quality in both assembly and service. The most common approaches are briefly reviewed.

Hardcoded values in application program cannot and need not to be changed, which may sound simple. But, in practice it prevents efficient re-use of the same design in multiple target positions, which violates the re-usability target of modern system design.

The **use of connector pins** was popular approach in the 1990s, but it has several problems. Re-usability is constrained, because supporting the full node-ID space and all bit-rates will reserve too many connector pins. Wiring is also prone to assembly errors and very unreliable in the long term. Typically special tools are required for making such connections inside the connectors. But the most significant problem, especially in service, is that a person with electricians expertise and electric drawings are required. In addition, parameters need to be downloaded, which leads to the use of two different approaches. Expertise is also needed to perform the tasks in a correct order.

Mechanical switches are comparable with connector pins from process and expertise point of view. It is known fact that switches tend to change state unintentionally under vibrations and shocks. Moreover, the use of switches requires at least one additional opening in the housing to provide access to the switches, causing additional sealing challenges and increased size of the node.

Coding plugs has not been so widely used. Supporting the whole node-ID space and all bit-rates will result huge number of different plugs, which will be a logistic nightmare. Also expertise is required, because correct plugs need to be read from electric drawings. The use of constrained number of node-IDs and bit-rates will decrease the re-usability of the nodes. Coding plug connector also increases the size of the node. Missing standard for such plugs may lead to the use of multiple different plug series for different devices, decreasing the logistics efficiency further.

Automatic bit-rate detection

sounds attractive, but the use of it requires one node transmitting at fixed bit-rate. If there is more than one node with a fixed bit-rate, a configuration challenge exists again. Instead, it increases complexity of the nodes and node-IDs and other parameters still need to be assigned separately. So, automatic bit-rate detection does not provide generic solution in a system level.

The **use of CANopen object dictionary** for setting bit-rate and node-ID keeps the nodes small and simple [4]. Mechanical unintentional changes are avoided and the overall way of working becomes simple – no electricians or other expertise is needed, because a download tool can read values from DCF files and download them into nodes. In theory there is a risk that an unintentional SDO transaction may corrupt bit-rate or node-ID. To protect against unintentional SDO transactions, manufacturers are using various keywords or other coding methods for the values. The use of such device-specific values introduces another challenge. Therefore the download tools need additional information, which is not stored into DCF files. Activation of the bit-rate and node-ID is not exactly described, but various activation timings are well supported by the current tools using point-to-point connection.

Layer setting services (LSS) provides the same benefits as using the object dictionary and also solves the problems with the object dictionary [6]. LSS defines exactly the procedures needed for setting bit-rate and node-ID, including activation. All parameter values are also standardized, which enables download tools to directly use the bit-rate and node-ID from DCF file without node specific values and procedures.

It can be concluded, that the most simple and efficient approach is to use CANopen selectable node-ID and bit-rate, preferably LSS. All other approaches have significant restrictions or they require special expertise. Node-ID and bit-rate need to be set before installation of the devices – all other parameters may be written in the same time.

- [6] *CANopen layer setting services (LSS) and protocols, CiA 305, CAN in Automation*
- [7] *CANopen electronic datasheet – Part 1: General definitions and electronic data sheet specification, CiA 306-1, CAN in Automation*
- [8] *CANopen electronic datasheet – Part 2: Profile database specification, CiA 306-2, CAN in Automation*
- [9] *CANopen electronic datasheet – Part 3: Network variable handling and tool integration, CiA 306-3, CAN in Automation*
- [10] *CANopen device description – XML schema definition, CiA 311, CAN in Automation*
- [11] *CANopen device profile for fluid power technology proportional valves and hydrostatic transmissions, CiA 408, CAN in Automation*
- [12] *EN 62061, Safety of machinery. Functional safety of safety-related electrical, electronic and programmable electronic control systems, 2005, p. 201*

Application programs are parameter values of domain type objects, when programs are downloaded according to CANopen [5]. Using CANopen conformant program download enables downloading the all required information in a single transaction.

Preparing for download

DCF-files cannot contain the all-necessary information for configuration downloads. In addition to the node-ID and bit-rate object values, hierarchical and human-readable position information cannot be included. Image can be linked by file name, but image name included into control file improves re-usability of the images. Traditionally, all required information is passed to assembly and service as text documents and parameters are written object by object. It is most efficient to download configuration from DCF files to the nodes [3]. Until now, the weakest points have been manually edited control files, manually created from templates. It is most efficient to generate such files directly from CANopen projects.

To enable automatic control file generation, sufficient information needs to be included into CANopen projects. The most impor-

tant thing is to define, what objects will be downloaded. By default, all objects with access type read-write (RW) are included – write-only (WO) objects are not included, because their values cannot be verified. Access type is fixed and if required, it can be overridden by setting the lowest bit of object flags to one to intentionally prevent the download [7]. System designer shall make sure, that parameter values are defined for all objects to be downloaded. The download tool shall not write to an object, if parameter value is not defined. Missing parameter values indicate that the design may not be ready.

System-subsystem-position-hierarchy is used in the user interface of the example download tool shown in Figure 5. Network name is by default used as both system and subsystem name and node name is used as a position name. If required, the names can be edited manually to more descriptive. The conversion tool adds instructions for the possible modifications as comments into corresponding locations of the control file.

If all objects need not to be or shall not to be written, e.g. factory calibration objects [3], they can be manually removed from the control file. Additional edit-

ing is not needed, if target node supports LSS. But if object dictionary is used to set node-ID and bit rate, corresponding objects and values need to be defined because it is impossible to automatically find absolute objects and values from the corresponding DCF file. In some nodes written value differs from the read value. Therefore the written values are defined separately and values used in verification are included as object parameter values.

Case example

Information storage into version control and product data management systems may vary among the system integrators and is not within the scope of this article. File-system-based proof of concept is presented instead.

```
01 @echo off
02 python "C:\...\pco2cpj.py" "%1nodelist.pco"
03 python "C:\...\dcf2cfg.py" "%1nodelist.cpj"
```

Figure 2: An example make.bat with node list transformation and download control file generation

A CANopen project in an example system design tool is presented in Figure 1. Project name is Simple_CANopen and there is a DCF file for each node for storing node configurations. Short node names are used, because they may be used as part of vari-

able names in application programmable devices and variable name length is typically limited. The example tool uses a proprietary node list file for combining DCF files into the project.

File generation can be implemented as a batch file combining several phases. Proprietary node list need to be converted first into a standard file to provide standard CANopen project for further processing. Example system design tool supports a make functionality, which calls the batch file with project path as a command line parameter. Same approach could also be used with tools not supporting make – e.g. an external CANopen tool command, toolbar button or desktop icon may be used instead. An example make.bat is presented in Figure 2.

Example conversion is made in two phases. In the first phase, conversion tool pco2cpj.py in line 2 generates a standard nodelist.cpj from proprietary nodelist.pco. The second conversion tool dcf2cfg.py in line 3 generates the configuration download control file templates from the DCF files. Path to the current project is passed as the first command line parameter. It is possible to include other conversions, e.g. for generation of analyzer setup files or node reference designator plate originals, into the same batch file. Project files are shown in Figure 3, where generated node list and DCF files are highlighted.

Configuration files need to be copied finally to the corresponding folders of the download tool. Dedicated folders for DCF, CFG and image files are used by the example download tool as shown in Figure 4. Fixed ▶

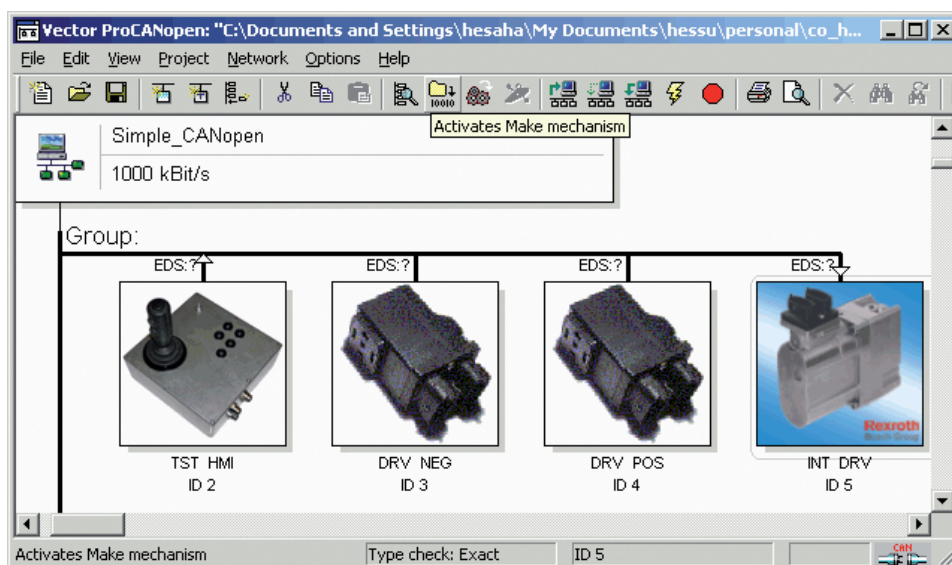


Figure 1: An example CANopen project with highlighted make.bat call



EtherCAN - A Linux Based Gateway

- EtherCAN Version 2.1 with increased performance
- Fast 32-Bit Processor Winbond W90N740CD
- 16MB SDRAM, 2MB Flash, 10/100MBit Ethernet
- Optional: Application Package with CANopen Master
- Optional: Application Development Kit

www.ems-wuensche.com

EMS Sonnenhang 3
 D-85304 Ilmmünster
 Tel. +49-8441-490260
 Thomas Wünsche Fax. +49-8441-81860

EPEC 2024 CONTROL UNIT NOW ALSO AVAILABLE WITH GL-APPROVAL

2024 CONTROL UNIT GL APPROVAL
 MARINE TYPE APPROVED: GERMANISCHER LLOYD

- SHOCK AND VIBRATION ENDURANCE 100G
- WATER AND DUST PROOF IP67
- SMALL FOOTPRINT
- PLCOPEN PROGRAMMING

Marine conditions?
BRING IT ON!

CANopen SAE J1939 ISOBUS e17 100G CodeSys CE GL



EPEC

EPEC OY | P.O. BOX 194 | FIN-60101 SEINÄJOKI | FINLAND | TEL. +358 20 7608 111 | WWW.EPEC.FI

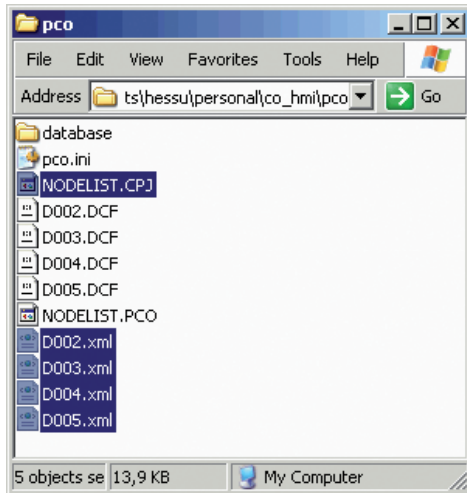


Figure 3: An example CANopen project folder with generated files highlighted

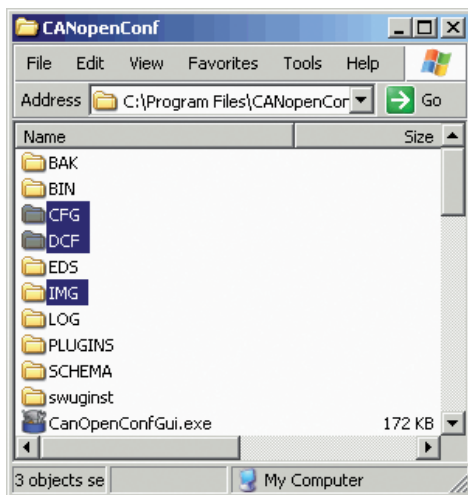


Figure 4: Example CANopen download tool folders with the folders for configuration files highlighted

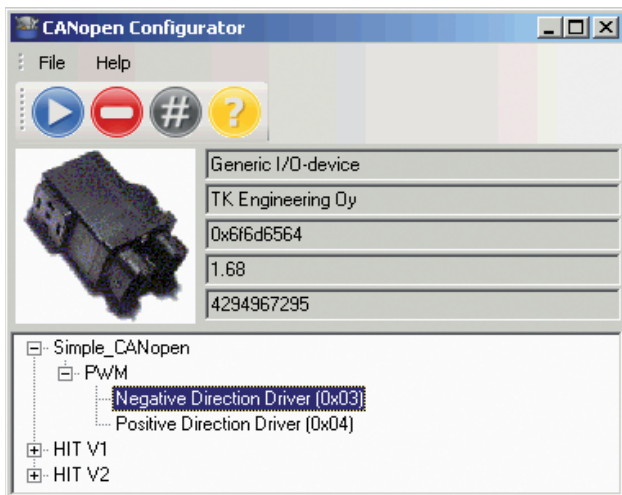


Figure 5: Example of selecting target position for a device connected to the download tool

folders are used, because the configuration download tool may be used in a PC or in a PDA without network connection, and database is too heavy to be used in a PDA. File copy can also be

automated, with e.g. previously presented make, but it depends on the storage approach, which is not within the scope of this article.

Configuration downloads are simple. First, op-

erator shall connect the device into the tool, turn power on and start the tool. Then, operator need to select the bit-rate, after which the tool reads the device identity and lists all defined target positions for such device. Finally operator can just select the desired position from the tree view and the tool downloads, stores and verifies the configuration, which may also contain application program(s).

In the example of Figure 5, position names are edited to maximize the understandability of the target positions. Only positions designed for device type and version of currently connected device are shown in the list. Short node names are replaced with long node names, which are more understandable. Also subsystem name was changed manually, because there is not corresponding standard entry available in the DCF file.

Concluding remarks

Incomplete designs cause always problems in assembly and service. When information management is automated, incompleteness of a design is more clearly indicated. All positive results are achieved by following standardized CANopen design process and files and automating the standardized information processing. Based on the evaluation in some real projects, any reasons for deviating from the process were not found.

All CANopen devices can be supported without any constraints. If a device supports standardized SW download interface, also application program(s) can be downloaded together with configuration in a single transaction. The download procedure operates in a plug-to-play principle [3] – plug the device to the download tool, plug the device to the target system and play. Special expertise is not required, operator need to

know only where he or she is going to assemble the device. The use of a device image for illustration of target position enables the use of the download tool even by alphabetic persons.

Average reached speed-up for preparing the download was measured to 15x, when some modifications to the control files – e.g. target subsystem name, object list and object details for bit-rate and node-ID – are needed. If the device supports LSS and only target sub-system names need to be changed, speed-up of 60x can be achieved. Absolute modification time for each DCF is less than 30 s in the latter case.

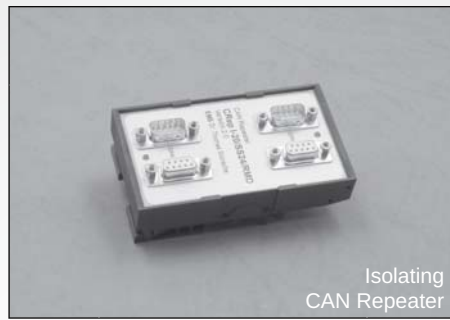
The first challenge was found from CiA 408 device profile [11], where object multiplexing is used in actual value conditioning. Such approach expects the use of multiple values for some objects, which is not supported by current DCF and XDC files. The most attractive solution would be to replace the object multiplexing approach with e.g. the use of array objects.

Second future development could be an improvement of the standard DCF and XDC files. With some additional entries the use of additional download control files could be avoided. At least a separate long name for node and a subsystem name are needed to improve the user interface of the download tool. As long as the use of LSS is not mandatory, details for setting bit-rate and node-ID through the object dictionary are needed.

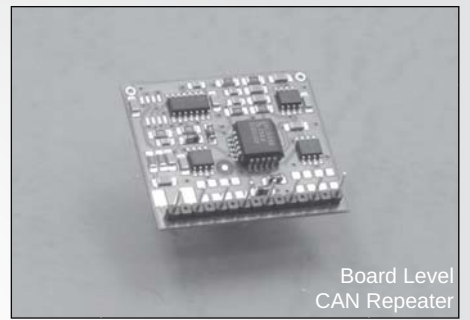
Third improvement could be introduced in CANopen program download. It is not currently included into the standard, how to activate the so-called boot-loader mode. It is handled by the existing tools, but the complexity of the tools could be reduced by improving the corresponding mechanism in CiA 302-3 [5].



Compact
CAN Repeater



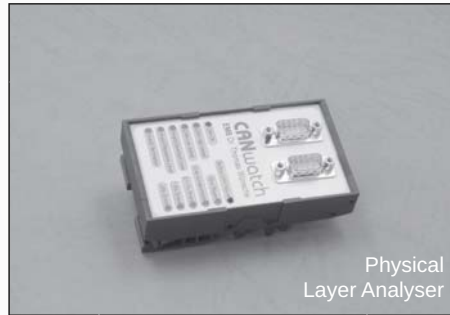
Isolating
CAN Repeater



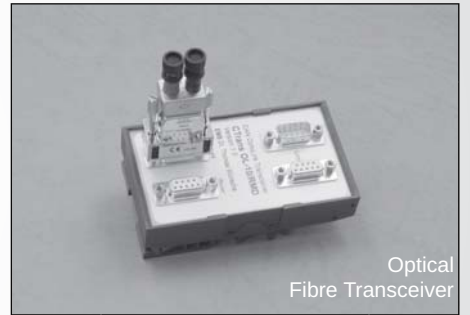
Board Level
CAN Repeater



Gateway
CAN/CAN



Physical
Layer Analyser



Optical
Fibre Transceiver

CAN Network Technology

Successfully applied in

- Machine automation
- Building automation
- Transportation systems
- Telecommunication systems

www.ems-wuensche.com

EMS Sonnenhang 3
D-85304 Ilmmünster
Tel. +49-8441-490260
Thomas Wünsche Fax. +49-8441-81860

TWK ELEKTRONIK

Switching Cam Encoders and Inclinometers ■ Linear Transducers and Rotary Encoders

With CANopen and CANopen Safety interface (SIL2 regarding IEC 61508) for engineering equipment, machinery and instrumentation



Switching Cam Encoders

Play-free electronic switching cam encoders instead of mechanical cam switches

Integrated electro-magnetic encoder

Position signal and output switches (max. 4) programmable via CANopen bus system



Inclinometers

Contactless, wear-free sensor system in MEMS technology

1 or 2 measuring axes

Selectable measuring range

Housing: aluminium or stainless steel



Inductive Linear Transducers

Measuring ranges up to 360 mm

Completely potted housing

Various mechanical designs to meet specific application requirements



Magnetic Rotary Encoders

36 to 50 mm diameter

Max. 13 Bit/360°

Housing: aluminium or stainless steel

With bootloader functionality

CANopen

CANopen
safety

www.twk.de | info@twk.de



Modular train communication system

Companies
 Sys Tec Electronic GmbH
 Railtec Systems GmbH

Links
www.systec-electronic.com
www.railtec-systems.ch

With introducing more multimedia services for customers and passengers in the transportation sector, demands on communication systems in trains are increasing, while the space available for electronics is often limited. To satisfy the need for performance in demanding applications and to close the gap to the ix86 platforms, SYS TEC Electronic (Germany) recently developed a 19-inch rack mountable communication platform.

The system was optimized for use in rolling stock applications and comprises a CPU module, backplane, power supply module as well as an I/O module. The system is compliant with EN 50155 Class Tx and allows for operation at temperatures from -40 °C to +70 °C without the need

for active cooling. Besides the electronic design, heat management issues turned out to be challenging. Dedicated heat spreading and heat sinking concepts were developed and implemented to allow for a safe operation within the specified operating conditions.

The CPU module is based on an on-module ECU core E660 system with a 1,3-GHz Intel Atom E660T MCU and a Linux board support package. It features a CAN port, two Gigabit Ethernet ports, two EIA-485/EIA-422 ports, EIA-232 as well as USB. The complementary middleware are CANopen protocol stack source code and Ethernet Powerlink protocol stack source code.

The module provides a basic memory configuration of 4 GiB on-board SSD and up to 2 GiB of DDR2-800 SDRAM. A separate on-board system diagnostics controller on the ECU core performs essential monitoring tasks, such as temperature surveillance and power-on management to ensure recovery from critical states, performs continuous supply voltage monitoring and provides a secondary watchdog timer.

The I/O Module provides eight digital inputs, two fast counter inputs, eight digital outputs and two analog inputs. The digital input and output channels

support an input voltage range from 24 V_{DC} to 110 V_{DC} including user-configurable filtering options, reverse polarity and overload protection. The analog input channels support input signals types from ±10 V, ±20 mA, 0 V_{DC} to 10 V_{DC} and 0 mA to 20 mA.

The power supply module supports an input voltage range of 24 V_{DC} to 110 V_{DC}. It provides VME-bus compliant voltage levels of 5 V_{DC} and 12 V_{DC} with up to 100 W output power to the backplane. VME-bus compliant signals as well as system-specific power fail event information are provided to the CPU module.

Although the developed modules can work with standard VME32 backplanes, their best performance is revealed with the Backplane that was developed specifically for this train communication system. It provides optimized heat-spreading and heat transfer characteristics and allows for use of standard VME power supply units.

The company designed the presented modules for Railtec Systems (Switzerland). The serial production is scheduled at manufacturer's production facility in Reichenbach (Germany). The firm offers automation solutions based on the IEC 61131-3, CAN, CANopen and Ethernet Powerlink. *Olga Fischer*



Figure 1: CPU module
 (Source: Railtec Systems)

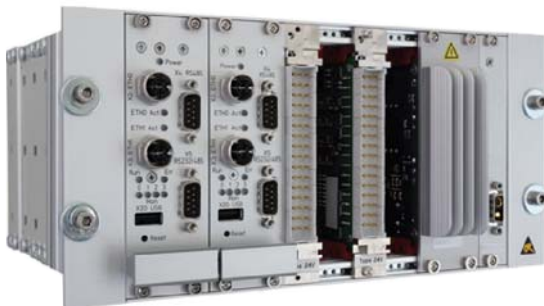
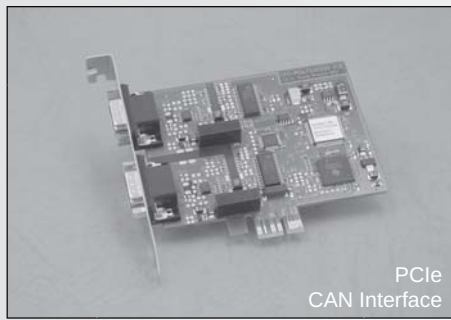


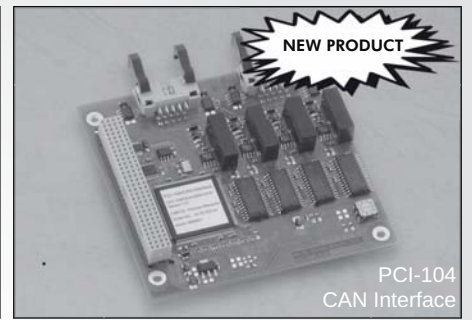
Figure 2: Train communication system
 (Source: Railtec Systems)



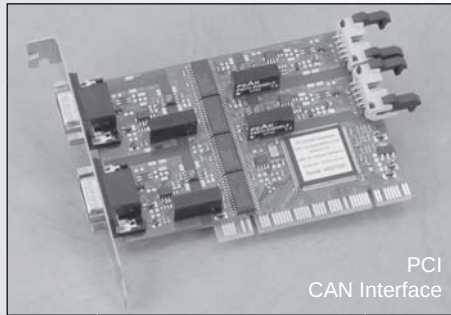
PCIe
CAN Interface



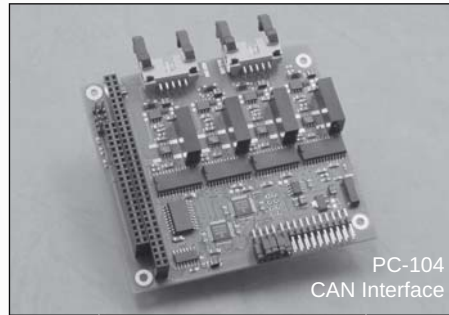
USB
CAN Interface



PCI-104
CAN Interface



PCI
CAN Interface



PC-104
CAN Interface



Ethernet
CAN Interface

CAN Interfaces for Your Requirements

- Economical solutions for series applications
- Optimized for industrial applications
- Solutions for stationary and mobile use
- Software support for bus-analysis, measurement and control

www.ems-wuensche.com

EMS Sonnenhang 3
D-85304 Ilmmünster
Tel. +49-8441-490260
Thomas Wünsche Fax. +49-8441-81860

EMBEDDED SOLUTIONS

CAN - LIN - TOOLS



LIN-BUS Issues ?

- ✗ access LIN equipped devices
- ✗ read, write and display data
- ✗ monitor bus signals and timing
- ✗ simulation of LIN master and slaves
- ✗ control bus from your PC application

BABY-LIN offers:

- compact and inexpensive solution
- isolated USB-LIN interface
- supports LIN V.1.2 to V.2.1
- direct access to LIN-bus via DLL
- execution on Windows and Linux PC
- operation with PC or standalone

Lipowsky Industrie Elektronik GmbH
Römerstr. 57 • D-64291 Darmstadt

Phone: + 49-(0)6151-93591-0 • Fax: -28
Contact: info@lipowsky.de • www.lipowsky.de

Distributed in the USA by DGE Inc.
2870 Technology DR • Rochester Hills • MI • 48309

Phone: 248-293-1300 • Fax: -1309
Contact: sales@dgeinc.com • www.dgeinc.com



Challenges for future vehicle networks using different voltage domains with regard to EMC

Gunnar Schulz, Adrien Schoof, Frank Schade

Authors

Gunnar Schulz
Adrien Schoof
Frank Schade

NXP Semiconductors GmbH
Stresemannallee 101
DE-22529 Hamburg
Tel.: +49-40-5613-0
Fax: +49-40-5613-62249

Link

www.nxp.com

In contrast to the requirements from the early 1990s when the on-board power supply had to serve only a few different components, the power consumption of the “classic component” (e.g. the engine starter) are pushed into the background compared to the components that are now found in today’s vehicles. Meanwhile the quantity of assistance, comfort, safety and infotainment systems has assumed proportions whose energy demands can only be met by car manufacturers through on-board power supplies with higher voltage, low-loss voltage converters and efficient energy storage devices. The principle architecture in Figure 1 shows that the communication between the control units crosses various voltage domains. It depicts an example of an electric vehi-

cle with one engine for each wheel.

In electronic and hybrid vehicles of the future, a second high-voltage on-board power supply will expand the 12-V on-board power supply, in order to be able to achieve energy-efficient vehicle system functions. Among other things, the high-voltage on-board power supply enables a reduction of CO₂-emissions through more efficient recuperation, optimization of the air-conditioning and heating output, as well as a general reduction in the vehicle’s weight through a more compact design, high-performance actuators, and the cable harness itself. With the existing 12-V voltage level and the mentioned high-voltage level, a dual on-board power supply is in development for hybrid and electric vehicles.

Independent of the relevant vehicle architecture, on-board power supply voltages greater than 12 V or 24 V result in a series of technical challenges to the networking of the vehicle. Today, most transceivers are designed for 12-V or 24-V environments only. Independent from the supply voltages, this means that on the bus side, vehicle networks with these transceivers are only resistant to interferences that commonly occur in 12-V or 24-V-based vehicle architectures.

However, future high-voltage on-board power supplies must take into account EMC-relevant interference scenarios, whose complete expression in vehicles is not yet known. These include ground shift or even loss of ground, reverse currents, and transient pulses as well as voltage surges. Through their expression in high-voltage systems, the phenomena place significant challenges on the transceivers and would lead to the destruction of most currently available components. In systems with voltages higher than 60 V, protection against contact is an important issue. It is thus absolutely necessary to shield and isolate voltages that are dangerous for humans in all places, which are accessible during the operation and maintenance of the vehicle. ▷

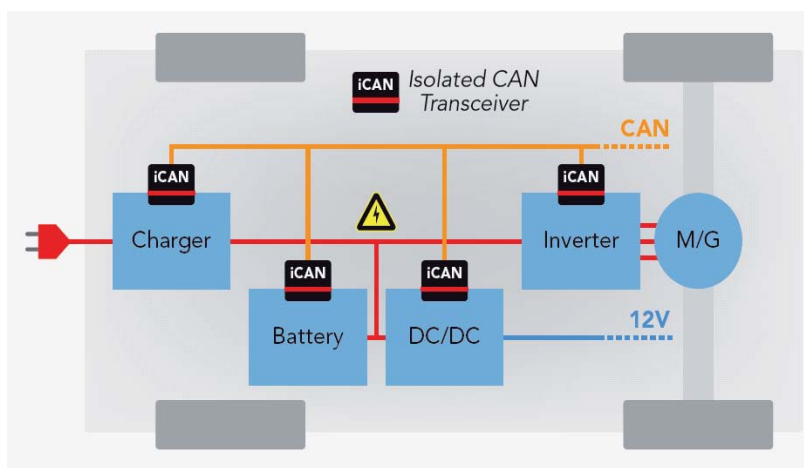
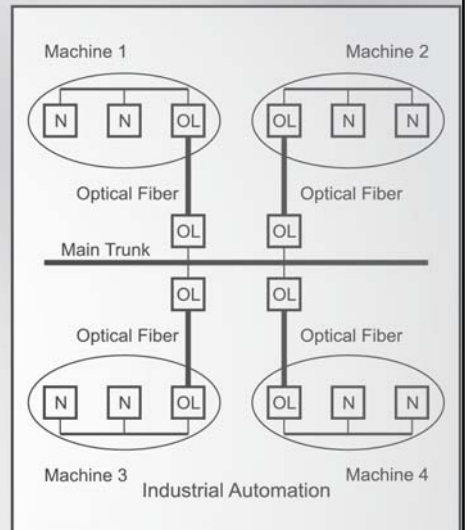
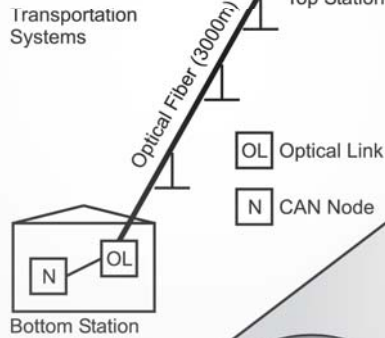
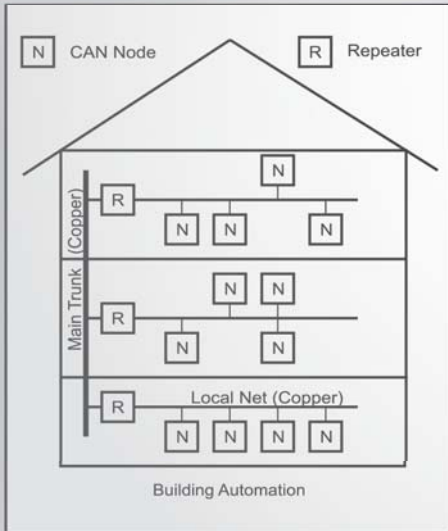


Figure 1: Networking of components in various voltage domains

Application: CAN Network Technology



www.ems-wuensche.com

EMS

Sonnenhang 3
D-85304 Ilmmünster
Tel. +49-8441-490260
Fax. +49-8441-81860



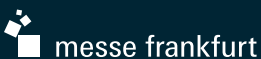
Innovations & solutions in automation
From sensors and control systems to applications
创新的工业自动化解方案
测量，控制一体化应用技术

4 - 6 March 2013
2013年3月4 - 6日

China Import and Export Fair Complex
Guangzhou, China

中国，广州
中国进出口商品交易会展馆

www.siaf-china.com



Abstract

A number of vehicle manufacturers has launched the first generation of their electric vehicles on the market and are now working towards developing them further. In order to increase their economy and with it gain acceptance from end users, the next generation of these vehicles must exhibit improvements with regard to energy management, reliability, and acquisition costs, and exhibit a reduction of risks through the ever-increasing system complexity. One key aspect is represented by the networking of control units, which are found in different voltage domains in an electric or hybrid vehicle. The main concern is to find cost-optimized solutions that also fulfill the higher demands with regard to electromagnetic compatibility (EMC) in addition to the functionality required. The focus is high-voltage-resistant, isolated communication that enables the individual voltage domains to be separated from one another, while simultaneously ensuring network functionality. Using an example of an isolated CAN transceiver, this article presents the main EMC requirements and the relevant network parameters. Solution approaches for the semiconductor industry are presented and evaluated.

Galvanic isolation

Adding new voltage domains in the vehicle requires galvanic isolation to be implemented in the network. The conventional isolation processes are compared in Table 1.

After assessment of advantages and disadvantages within the system context, NXP implemented capacitive isolation in a CAN transceiver. This solution incorporates the advantages of low current consumption, short processing times, and stable pulse widths. Through appropriate implementation, the sensitiv-

ity to HF (high frequency) fields present at capacitive isolators was able to be limited to a non-application relevant degree.

The TJA1052i [1] belongs to the third-generation of company's high-speed CAN transceivers. It combines a galvanic isolation of up to 5000 VRMS with the EMC characteristics of non-isolated CAN transceivers. The transceiver is in compliance with ISO 11898-2 and has a loop delay of 220 ns including isolation, which enables a maximum bit-rate of 1 Mbit/s in automotive networks.

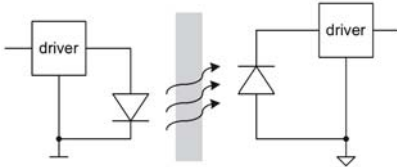
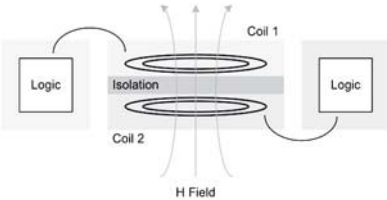
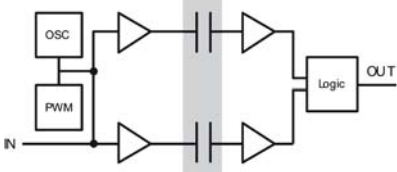
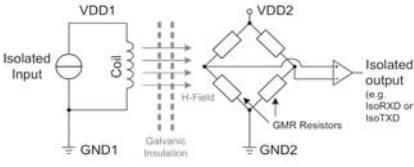
<p>Optical isolators</p>  <ul style="list-style-type: none"> ◆ Quasi-standard for galvanic isolation of electric systems ◆ Signal transmission: direct and slow alternating signals ◆ Fast optocouplers (up to 50 MHz; only as 5 V-version) available ◆ Sensitive to parasitic capacitive coupling paths and crosstalk ◆ Not sensitive to external electric or magnetic fields ◆ Long signal throughput times of 60 to 100 ns ◆ Aging of the isolation layer lengthens the signal throughput times ◆ High power consumption 	<p>Inductive isolators</p>  <ul style="list-style-type: none"> ◆ Used as current and voltage transducer for energy transmission ◆ Signal transmission: modulated direct and slow alternating voltages of less than 150 MHz ◆ Sensitive to external variable magnetic fields ◆ Impulse width compliance is difficult due to the inductivity and the crosstalk of adjacent inductors ◆ Immunity to common-mode interferences ◆ Average signal throughput times ◆ Low power consumption
<p>Capacitive isolators</p>  <ul style="list-style-type: none"> ◆ Feasible with standard technology ◆ Signal transmission: modulated direct and slow alternating voltages of less than 150 MHz ◆ Sensitive to external HF-fields ◆ Short signal throughput times ◆ Low power consumption 	<p>Giant magnetoresistive (GMR) isolators</p>  <ul style="list-style-type: none"> ◆ Construction: exciter coil and GMR detector element ◆ Magnetic field is proportional to the electricity ◆ Signal transmission: direct and alternating signals ◆ Short signal throughput times ◆ Undefined condition of the output signals when connecting to the power supply

Table 1: Overview of the most important galvanic isolation techniques

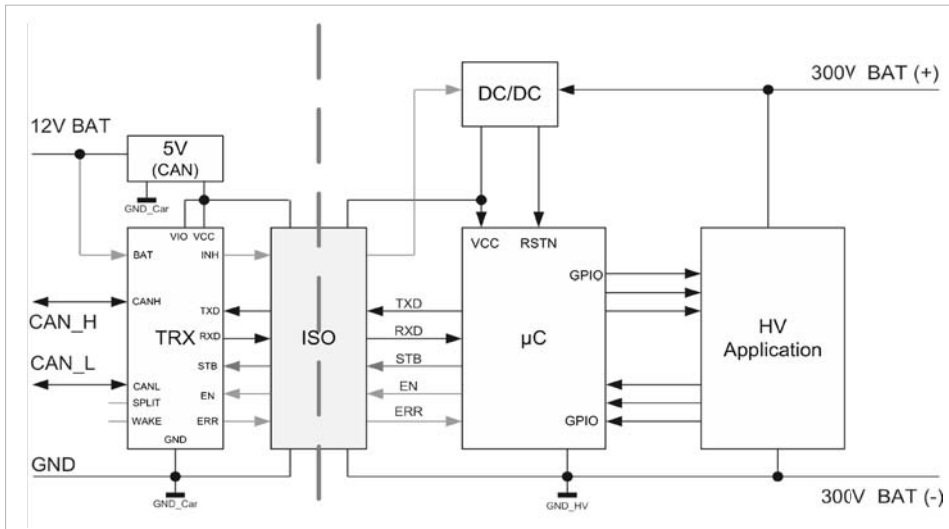


Figure 2: Galvanic isolation of various voltage domains using CAN transceivers

Future transceivers will most likely be located directly at the interface between the different voltage domains. This is shown, for example, in Figure 2, where the isolation between the transceiver and microcontroller is implemented. Worth mentioning here are the CAN bus networking of the battery sensors and the generator as well as the networking between the electric engine and the hybrid engine control. In classic monolithic transceivers, a bus-side voltage robustness greater than 60 V is not economically feasible for a variety of reasons. Isolation for the purposes of protection against contact would likewise not have been present.

A possible solution for a functionally reliable networking of vehicle sub-systems that are located in different voltage domains is represented by integrated galvanic isolated transceivers. When the correct choice is made, these combine the advantages of optimized transceivers and those of the galvanic isolation without having to compromise functionality, safety, or EMC.

Since sub-systems in the vehicle are sometimes distributed over a greater distance, isolation that avoids ground loops and protects the systems against high voltage puls-

es is advised. Galvanic isolation also reduces signal distortion. In addition to protecting against high voltages, corresponding transceivers thus contribute towards increasing the robustness of the bus system by ensuring the signal integrity. An interrupted signal transmission means that bus system performance is decreased, messages are sent multiple times, or system responses are delayed. This effect increases with the number of nodes in the network.

EMC characteristics of the CAN isolators

Ensuring the EMC in automobiles is covered by a variety of integrated circuit (IC) components and vehicle

measurement methods. For the EMC qualification of isolated transceivers, the standards IEC 61967 [2] for electromagnetic emission and IEC 62132 [3] or ISO 7637 [4] for electromagnetic immunity are applied [5]. Many car manufacturers demand these qualification results in their internal specifications before they decide on additional tests and the approval of the transceivers.

Regardless of the concept of the isolator, all requirements for conventional transceivers still need to be fulfilled. The EMC test specifications for CAN transceivers are based on the following approach:

- ◆ Construction of a minimal network on a test board

- ◆ Use of simple network communication
- ◆ Interference coupling or decoupling of radiated narrow-band interferences and transients on the basis of IC measurement methods
- ◆ Assessment of the functionality based on different voltage-time curves [6]

Ideally, the EMC characteristics of a CAN transceiver with an isolator are retained such that existing filter concepts of vehicle components with CAN modules are able to be adopted. In accordance with the electromagnetic coupling of the transceiver with the vehicle and the control unit itself, only the pins that show a direct connection to the cable harness ("global pins" such as bus pins, VBat, global wake entries) are considered with regard to interference coupling or decoupling. Isolated CAN transceivers that are currently available only have local power supply pins and no wake pins. Therefore, this article only concentrates on CAN pins.

Conducted electromagnetic immunity

An important EMC parameter for isolated transceivers is the immunity against ▶

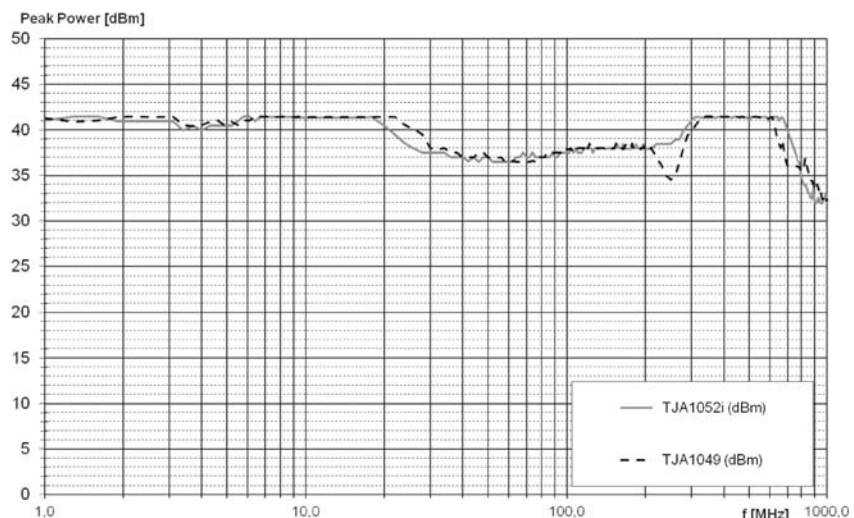


Figure 3: Comparison of radio frequency (RF) immunity (without additional filter elements) between a conventional (TJA1049) and an isolated CAN transceiver (TJA1052i)

Transceiver	Mode	Coupling	Evaluation	Pulse Tolerance [V]			
				1	2	3a	3b
TJA1052i	Normal	CANH/CANL	RxD	-95	>75	-75	>100
TJA1049	Normal	CANH/CANL	RxD	-90	>75	-60	>100

Table 2: Immunity to transients (without additional filter elements) between a conventional CAN transceiver (TJA1049) and an isolated CAN transceiver (TJA1052i)

conducted interferences. The electromagnetic immunity describes the inability of a device, equipment or system to perform without degradation in the presence of an electromagnetic disturbance. On the basis of IEC 62132-4, comparison measurements of electromagnetic immunity were carried out between conventional third-generation transceivers from NXP and the TJA1052i. Figure 3 shows the corresponding measurement curve of a conventional (TJA1049) and an isolated (TJA1052i) CAN transceiver. The results show only minor differences with regard to electromagnetic immunity in the frequency range observed. Electromagnetic immunity of 36 dBm was required as a development goal for frequencies above 10 MHz. In order to analyze safety margins, measurements were carried out even up to 41 dBm.

It can be concluded from the minor differences between the two curves that the isolator part of the TJA1052i has no effect on the immunity. The characteristics of the curve are mainly determined by the transceiver.

An additional immunity test for semiconductors is the susceptibility to transients according to ISO 7637. Transient impulses in the on-board power supply occur through the switching of loads or inductors. The standard distinguishes five types of impulses, which are differentiated in amplitude and length. Pulses 1, 2, and 3 – applied to the appropriate bus pins – are par-

ticularly important for CAN transceivers. Table 2 shows the results.

The transient measurement delivers results that are similar to the conducted immunity tests. The differences are minor and allow for the same conclusion – that the immunity is determined by the CAN transceiver. The minor differences in the immunity testing can be traced to marginal modifications in the CAN block. The isolator itself has no influence on the results.

Conducted electromagnetic emission

The previous results show that the proven IC measurement processes regarding immunity are also applicable to isolated CAN transceivers and lead to results that are comparable to conventional transceivers. Emission is discussed below in accordance with IEC 61967-4, and whether this IC measurement method is suitable. The electro-

magnetic emission constitutes the undesirable characteristic of an electric or electronic device as functioning like an electromagnetic source of interference, thereby potentially disrupting other devices. In this measurement, the same transceivers as in the electromagnetic immunity test were used. The comparison in Figure 4 shows only minor differences in the spectrum. The isolator in the TJA1052i has no influence on the emission here either. The characteristics of the curve are determined solely by the CAN transceiver and not by the isolator.

Transfer impedance

In a conventional transceiver, the signal emitted is diverted both to the dominant and to the recessive state from the supply voltage and the transceiver ground. High-frequency interferences on the power supply or ground within a control unit are thereby transferred to a

bus and, with that, to the vehicle. In particular for common-mode interferences of the power supply net an effective filtering is subject to limits.

At this point, a special EMC advantage of the isolated CAN transceiver comes into effect. The galvanic isolation of transceivers ensures an additional damping between the isolated voltage domains, as was described at the outset. This positive characteristic over conventional transceivers means that the electromagnetic emission from the power supply voltage or ground leading from control units to the bus and vice versa are damped. With this, couplings of interferences from different voltage domains are effectively suppressed from one side to the other.

Figure 5 represents the transfer impedance measurements (S21 measurement) of different conventional and isolated CAN transceivers available on the market. In order to minimize foreign influences on the measurement results, the tests were carried out directly on the respective pin and thus without voltage supply or an additional circuit board. The lower array of curves shows the isolated transceivers. It is evident that these show an additional damping of approximately 10 dB in comparison to

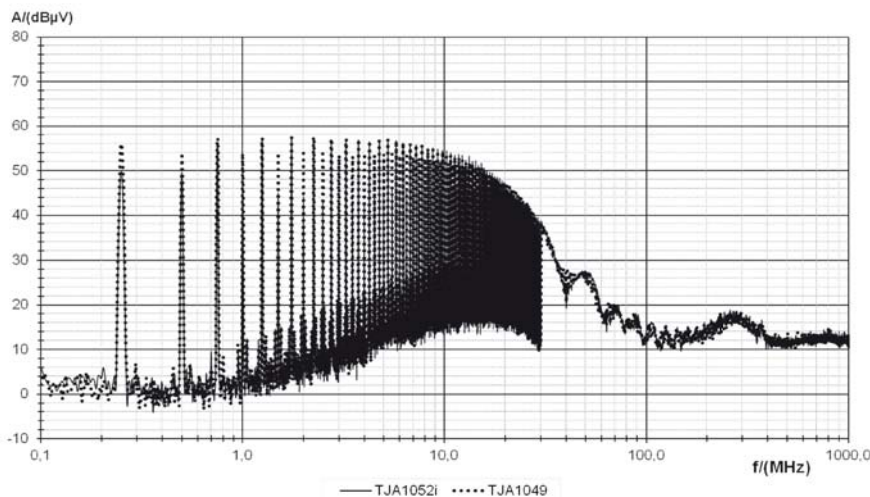
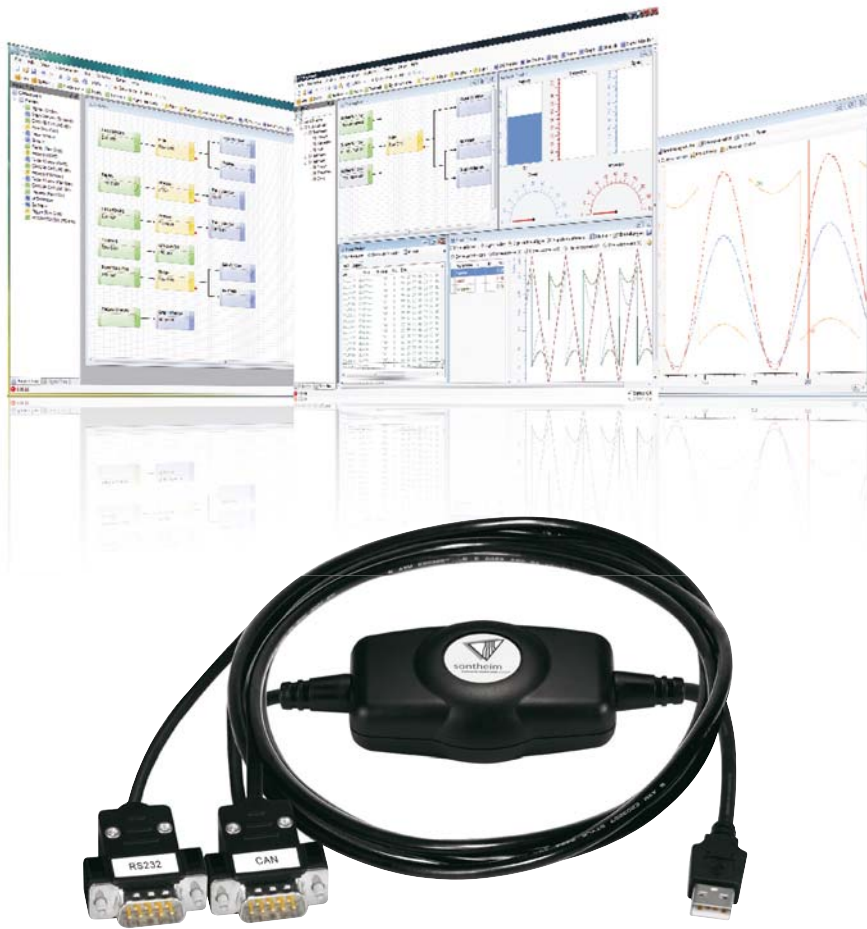


Figure 4: Comparison of bus emission (without additional filter elements) between a conventional (TJA1049) and an isolated CAN transceiver (TJA1052i)



A Powerful Team for CAN-Bus Diagnostics



CANexplorer 4

- ▼ User-defined test setups with function elements and Drag&Drop
- ▼ Graph for CAN data visualisation
- ▼ Protocol support for J1939, CANopen® and others
- ▼ All common features like trace, log, filter and trigger for fieldbus diagnostics
- ▼ Signal editor for customer-specific protocols
- ▼ Import and export of signal data bases

CANfox

- ▼ 1x RS232 & 1x CAN galvanically isolated
- ▼ Connection to PC via USB 2.0
- ▼ Powerful 32Bit micro-controller
- ▼ CoDeSys gateway driver available
- ▼ Multi-Thread API available
- ▼ Highly attractive pricing

We live electronics!

For more information visit our new website and order online!

www.sontheim-industrie-elektronik.de

Sontheim Industrie Elektronik GmbH
Georg-Krug-Str. 2 - DE - 87437 Kempten
Tel: +49 831-57 59 00-0 - Fax: -73
info@s-i-e.de

Interfaces



Diag-
nostics



Industrial-
PCs



IO-modules



PLCs



Motion
Drives



Terminals



Printing
Systems



Protocol
Stacks



Your
solution

Hardware
Software

Summary and outlook

This article demonstrates the challenges to future vehicle networks in different voltage domains with the EMC playing an important role. A high-voltage-resistant and isolated communication between the voltage domains, with secured network functionality, is the basis for the safe interaction of systems in future automobiles. The isolated TJA1052i transceiver suits in terms of isolation, functionality, and safety for today's requirements in respect to immunity and emission. It has no influence on interoperability and offers good damping properties between the voltage domains, which further reduces cross-talk interference. An adaptation of the currently valid EMC measurement methods and limits has been discussed. For the observed CAN transceiver, the previous assumptions, methods, and limits apply. A corresponding adjustment to current standards and limits has not been ruled out. Additional studies of potential sources of interference and the categorization of critical frequency bands that are expected to be implemented in hybrid and electric vehicle systems will be of importance.

conventional transceivers between the power supply voltage pins and the CAN bus.

In order to demonstrate an effective damping of interferences in an applicative environment, specimens of some transceivers with circuit boards and voltage supply were measured in the dominant state. The results are depicted in Figure 6. Here the damping amounts to between 5 dB and 15 dB in comparison to conventional transceivers depending on the frequency

range and external influences of the application. This result confirms the measurement result from Figure 5 of approximately 10 dB in an idealized environment. It can also be noticed that the curves are higher in absolute terms, which is explained by the low-impedance coupling of the CAN bus and by the power supply voltage in the dominant state and the output stage of a transceiver.

Therefore, if using isolated CAN transceivers between various volt-

age domains, it can be expected that an additional interference damping at a magnitude of 10 dB will be achieved. This provides a significant contribution for increasing the robustness of the bus system.

Measurement results summary

The results of the immunity and emission show that in an appropriate concept of the isolated transceiver, these factors are independent from the isolation ▶

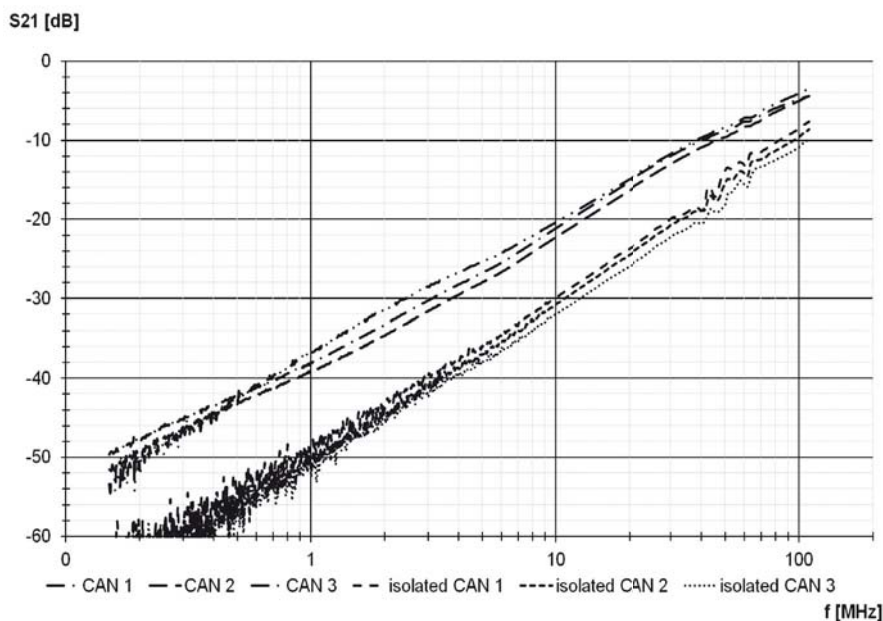


Figure 5: Comparison of pin transfer impedance from VCC to CAN_H for different conventional CAN transceivers (upper array) and isolated CAN transceivers (lower array)

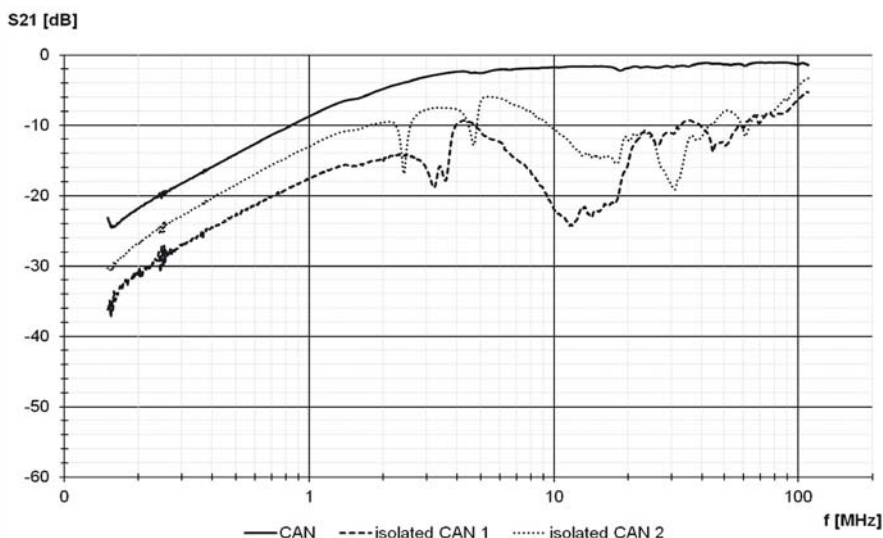


Figure 6: Comparison of transfer impedance in an applicative environment from VCC to CAN_H of a conventional CAN transceiver (upper curve) and two isolated CAN transceivers (lower curve) in the dominant state

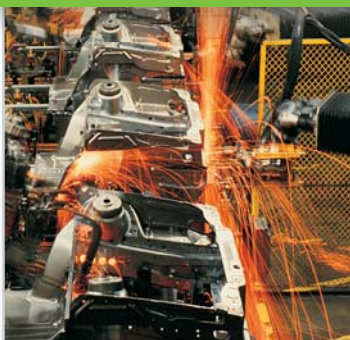
WIRELESS CAN INTERFACES



rmcan.com

CANlink Bluetooth / WLAN & CANview GPS
Connecting. Monitoring. Positioning.

WIRELESS CAN DATA TRANSMISSION



Remote control in industrial environments

Replace cables

The wireless interfaces CANlink Bluetooth / WLAN are ideal for facilitating diagnostic applications and for making your CAN networks independent from physical connections. With the RM PC tools, you can easily configure the devices or monitor and visualize all CAN data.

RM CANlink Bluetooth / WLAN are especially practical for mobile, but also for stationary applications: Use them as a gateway to transmit data wirelessly between a CAN network and a PC, laptop or smartphone with the respective functionality. Or configure two CANlink Bluetooth or WLAN devices as a bridge to interconnect CAN networks without any cables or plugs.



CANlink® Bluetooth

Thanks to the standard Bluetooth protocol, the connection to other Bluetooth devices can be established and maintained easily. Additionally, frequency hopping and transmitting small data segments lead to high connection stability. CANlink Bluetooth is compatible with Windows and Android: Thanks to sample codes, you can develop your own applications or use the provided basic Android app for viewing CAN messages.

CANlink® WLAN

CANlink WLAN can be operated in two different modes: In ad-hoc mode, devices with WLAN functionality directly connect to each other. In infrastructure mode, the interface establishes a data connection using one or more WLAN access points. That is, it can hop from access point to access point and maintain a continuous connection, so that the CAN network or bridge is extendable along the entire WLAN infrastructure and via the Internet – with an unlimited range.

Mechanical Data	CANlink Bluetooth 2001	CANlink Bluetooth 2103	CANlink WLAN 2001
Dimensions width / height / depth	138 / 60 / 35 mm		
Degree of protection	IP 65		
Temperature range	-40 °C ... +75 °C		-25 °C ... +60 °C
Weight	200 g		
Electrical Data			
DC power supply	10 V – 33 V		
Power input (@ 24 V)	60 mA		110 mA
Status LEDs (2 colors)	4		
Interfaces / Protocols			
CAN	1 (ISO 11898-2 high speed, on request: galv. isolated)		
Bluetooth / WLAN	2.0, Power Class 1, Serial Port Profile / -		- / 802.11b/g (11/54 Mbit/s), TCP, Security: WEP/WPA/WPA2
Range (open ground)	100 m		
CANopen®, Layer 2	✓		✓
Input / Output	-	- / 1x relais	-
Product Number			
CANlink® Bluetooth / WLAN	253 001 030	253 001 036	253 001 029
Certifications			
CANlink® Bluetooth / WLAN	CE, FCC		

For more details please visit rmcan.com



POSITIONING AND LOCAL GPS DATA OUTPUT



Determine GPS coordinates



GPS-to-CAN

CANview GPS is an ideal and cost-effective solution for worldwide positioning in all applications in which GPS data primarily shall be available on the spot, such as in surface mining or road tests. RM provides software for configuring the devices and evaluating the GPS data. Both models are IP 65-rated and thus suitable for use under harsh environmental conditions.

CANview® GPS 2107

CANview GPS 2107 not only outputs the GPS data on the CAN bus but also on its RS-232 interface. Additionally, the device features an integrated data flash for logging GPS data. You can further determine trigger points or sections between two trigger points which are marked or counted whenever they are crossed. A dbc file allows for integrating the CAN messages into the Vector tool chain.

CANview® GPS 5107

CANview GPS 5107 devices feature a robust, easy-to-install aluminum enclosure which can be bolted to a panel or mounted to a DIN rail TS35. With the RMsys Configurator tool, you can freely configure the device, including the CAN message settings. An integrated capacitor-buffered real-time clock further allows for setting timestamps.

Mechanical Data	CANview GPS 2107	CANview GPS 5107
Dimensions width / height / depth	128 / 85 / 35 mm	126 / 120.5 / 42 mm
Degree of protection	IP 65	
Temperature range	- 30 °C ... +75 °C	
Weight	260 g	510 g
Electrical Data		
DC power supply	10 V – 30 V	6 V – 32 V
Power input (@ 24 V)	95 mA	60 mA
Real-time clock with backup capacitor	-	Backup time 24 hours (typical @ 25 °C)
Logging memory	8 MB	-
Status LEDs (2 colors)	5	3
Interfaces / Protocols		
CAN	1 (ISO 11898-2 high speed)	1 (ISO 11898-2 high speed, 2.0 A/B)
RS-232	1	-
GPS tracking capability / accuracy	50 channels / 3 m (CEP)	22 channels / 3 m (RMS)
CANopen®, Layer 2	✓	
Product Number		
CANview® GPS	253 004 020	253 004 043
Certifications		
CANview® GPS	CE, FCC	

For more details please visit rmcan.com



SOFTWARE & ACCESSORIES

RM Bluetooth App

The RM Bluetooth Demo App enables you to connect to a CANlink Bluetooth device with your Android tablet or smartphone and to view CAN messages in a list. It features a connection manager and can be extended to interpret the received data, if desired in an individual user interface, or – depending on the application – even to actuate processes.

Any data transmitted in the connected CAN network can be viewed, such as axle load, trailer weight, engine rpm, coolant temperature, fuel level, driver status, or whatever is required in your application.

You have the possibility to extend and individualize the provided sample code on your own, using a free development environment. Or you can have us develop a custom solution specially tailored to your needs.

Please contact our sales team for more details and individual advice.



RM Bluetooth App - Access CAN networks via tablet or smartphone

Software & Accessories

In order to facilitate start-up and operation, we provide you with a wide range of software and accessories optimally tailored to our devices: from cables, mounting sets and special software tools to Starter Kits containing all components required for smooth commissioning.

Below, you can find some of the available Starter Kits. For a wider range of devices please see our website.

The RM Software Tools enable you to freely configure our devices without any programming skills and to visualize and monitor CAN data on computer or display screens – with individual screen design options.

Starter Kits

CANlink® Bluetooth 2001



Starter Kit product no. 253 000 055

CANlink® WLAN



Starter Kit product no. 253 000 059

CANview® GPS 2107



Starter Kit product no. 253 000 058

CANlink® Bluetooth 2001 Bridge



Starter Kit product no. 253 000 056

CANlink® WLAN Bridge



Starter Kit product no. 253 000 060

CANview® GPS 5107



Starter Kit product no. 253 000 107

Superior Quality
MADE IN GERMANY



**RM MICHAELIDES
SOFTWARE & ELEKTRONIK GMBH**

Headquarters
Donastr. 14
36043 Fulda, Germany

Phone: +49 661 9490-0
Fax: +49 661 9490-333
info@rmcan.com, rmcan.com



**RM MICHAELIDES
SOFTWARE & ELECTRONIC CORP.**

US Subsidiary
711 E. Monument Ave., Suite 310
Dayton, Ohio 45402-1490, USA

Toll-Free US: +1 877 RMCAN-US
Phone: +1 937 558 2211
Fax: +1 937 641 8787
info@rmcan.com, rmcan.com

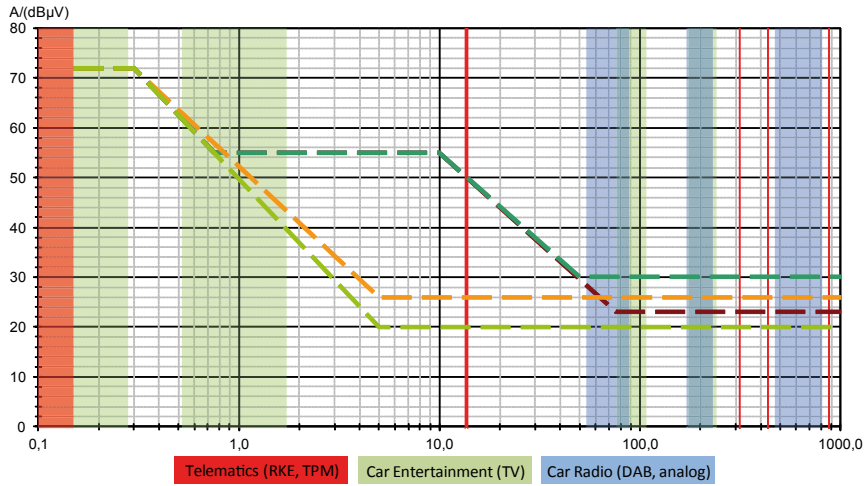


Figure 7: Sensitive frequency ranges with limit curves from German OEMs

and only dependent on the CAN block implementation. It was found out that isolated transceivers offer the additional advantage of good damping and thus reduce cross-talk interference between the voltage domains.

New EMC measurement methods are not yet needed

Today's methods for conducted EMC measurement for transceivers in the automotive sector have proven themselves capable of predicting the behavior of transceivers in an applicative environment – and therefore in vehicles. The methods were applied in the isolated transceivers described and their measurement results continue to underscore their validity. The practical experience with isolated transceivers in various voltage domains still has to confirm this. New methods and limits are currently not required, which has a positive economic aspect. However, a new discussion cannot be ruled out.

The system complexity is increasing in the individual control units, as well as in the entire future vehicle. More and more functions and additional communication systems are finding their way into the vehicles of the future. For example, “car-to-car” and “car-to-infrastructure” com-

munication, Wi-Fi Internet, and emergency call services such as eCall in Europe or OnStar in North America should be mentioned here. The exchange of information in the vehicle – and from the vehicle to its environment – will increase substantially.

As the integration of additional functions in vehicles increases, the number of potential sources of interference in sensitive frequency bands will also increase to the same degree. Sensitive frequency bands are frequency ranges in which electronic components may not disturb other components; these presuppose a lower potential of electromagnetic emission. The VHF (very high frequency) radio frequency range is a prominent example. Additional sensitive frequency ranges could play an even more important role in the development of automotive electronics in the future. On the other hand, higher limits with regard to electromagnetic emission in the vehicle could be permitted in other frequency ranges with less significance. Figure 7 demonstrates these circumstances using the currently valid limit curves from German OEMs [7]. Some critical frequency ranges in the vehicle are shaded in gray.

But even hybrid and electric vehicles with their electronic monitoring and

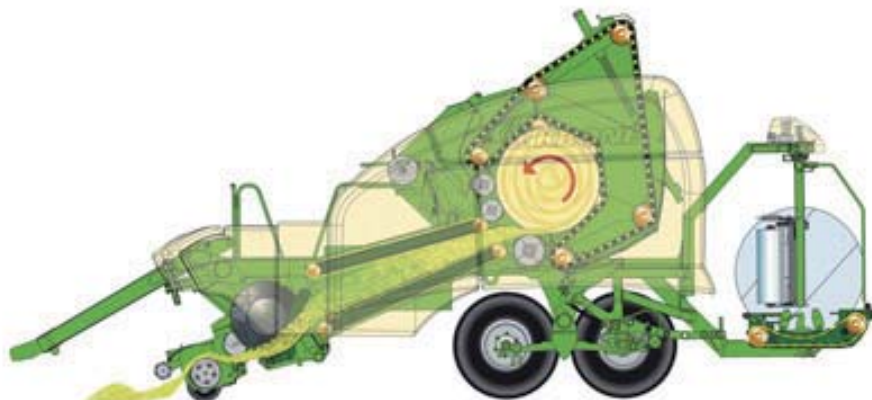
charging systems present new challenges with regard to EMC. The main sources of interference in such vehicles are the electric motors, which are mostly constructed as three-phase machines. Further noise sources are converters, which generate a three-phase alternating voltage from the high-voltage-supply, and DC/DC converters, which are used instead of alternators to generate the on-board voltages. Additionally high-voltage-driven auxiliary components are used [8].

All previously described components generate voltages, currents, and corresponding flanks, in part with new frequency components that must be considered. The frequency range between 2 kHz and 150 kHz, in particular, could play a larger role in future tests [9]. If this frequency range should actually prove to be critical, the corresponding immunity tests in the range below 1 MHz would have to be discussed. Multiple international groups are working on standards in order to overcome the future challenges. Practical experiences have made a significant contribution here. ◀

References

- [1] “TJA1052i, Galvanically isolated high-speed CAN-transceiver”; Objective data sheet; Rev. 0.04, NXP, January 20, 2012
- [2] IEC 61967, Integrated circuits – Measurement of electromagnetic emissions, 150 kHz to 1 GHz
- [3] IEC 62132, Integrated circuits – Measurement of electromagnetic immunity, 150 kHz to 1 GHz
- [4] ISO 7637-2: 2004, Road vehicles – Electrical disturbances from conduction and coupling – Part 2: Electrical transient conduction along supply lines only
- [5] GIFT ICT paper: EMC Evaluation of CAN Transceivers, version 03/02; IEC TS 62228, version 02/07
- [6] EMV-Grundsatzuntersuchungen zur Einführung des Flexray-Bus-systems [Basic EMC Tests for Introducing the Flexray Bus System]; FTZ an der Westsächsischen Hochschule Zwickau, 2008, Dr.-Ing. B. Körber, Dipl.-Ing. R. Kunz.
- [7] Hardware Requirements for LIN, CAN and Flexray Interfaces in Automotive Application; Audi, BMW, Daimler, Porsche, Volkswagen – Revision 1.2, 2011-03-25
- [8] EMV von Elektro-Hybridfahrzeugen (EMC of Electric Hybrid Vehicles); Hillmer, Volkswagen AG, GMM Symposium Munich, 2009
- [9] Focus Group on European Electro-Mobility; Standardization for road vehicles and associated infrastructure, CEN/CENELEC, version 2, 2011. Link: ftp://ftp.cencenelec.eu/CEN/Sectors/List/Transport/Automobile/EV_Report_incl_annexes.pdf.

Conference on electronics in mobile machinery



Links

www.vdi-wissensforum.de
www.elektronik-auto.de

“Baden-Baden Special”

This conference organized by VDI-Wissensforum, a daughter of the VDI association of German engineers, comprised three events:

- ◆ 5th conference on electronics in road cars
- ◆ 3rd conference on electronics in commercial vehicles
- ◆ 1st conference on electronics in mobile working machines.

The event took place in Baden-Baden (Germany) in October (10th and 11th).

About 500 participants attended the conferences and visited the joint exhibition. Next year the international VDI “Electronics in vehicles” congress will take place in Baden-Baden in October (16th and 17th).

The Tractor Implement Management (TIM) allows for example a baler to communicate with tractor via the Isobus network allowing the operator to adapt tractor speed automatically to the load on the baler and to prevent overload on the machine

The first session collected more attendees than the room’s capacity of some 160 seats. Peter Hieronymus (Claas) and Dirk Jahn (Putzmeister) introduced general trends and challenges for the electronics in agriculture vehicles respectively in construction machines. One common topic was the introduction of functional safety. But both industries reference different standards, which leads to different solutions. By the way, also in the both other conferences, functional-safety was an important, not to say the dominating, topic.

In one of the speeches, TTTech presented a safety-related controller compliant with ISO 13849 and IEC 61508 respectively IEC 62061. The carmakers have an own safety standard (ISO 26262), which is supported by some micro-controllers implementing specific safety circuitry (see “ISO 26262 compliant micro-controllers”). The agriculture machine industry has also its own safety standard: ISO 25119. Johannes Lange working with

Claas, explained in his paper requirements and applications of functional safety in agriculture engineering. For implements controlling the tractor a safe communication via the Isobus is required, which meets the Performance Level c. It is achieved by transmitting a running number in the periodically transmitted CAN frame. In construction machines, the CANopen Safety protocol is a possible candidate for safe communication. The Institute for Occupational Safety and Health (IFA) has approved this protocol for application up to the Safety Integrity Level 3 comparable with the Performance Level d or e.

Agriculture as well as construction machines make use of CAN-based networks. While in diesel engines commonly the J1939 protocol is preferred, the construction machines often implement CANopen as higher-layer protocol. The agriculture machine industry has developed an open network approach, trademarked as Isobus and internationally standardized in the ISO 11783 series.

Jan Horstmann (Krone) presented Isobus implements (e.g. harvesting machines), which control the speed of the truck via the CAN network compliant with ISO 11783. Of course, wireless truck-to-truck communication was also an important topic: Fendt (Agro) reported about a driverless truck, which follows a manned truck automatically.

Martin Rajek (Liebherr) explained his understanding on long-term and sustainable concepts for mobile machinery. It was a more philosophical paper with a lot of interesting views (e.g. that a software update or review may increase the value of machine during its lifetime). One of the challenges he addressed is the management (testing and validation) of control system variants. This is the same in agriculture and construction machinery: The volume is low and the number of specific solutions is high. Also other speakers (e.g. from Bosch Rexroth, Krone, and TTTech) spoke about the need of scalable control devices, and presented their solutions. ▶

ISO 26262 compliant micro-controllers

Exida (www.exida.com) has certified Freescale's Qorivva MPC5643L micro-controller (MCU) to be compliant with the ISO 26262 functional safety standard. The 32-bit MCU with CAN on chip is designed for use in automotive applications that require automotive safety integrity levels (ASIL) up to D. Typical applications include electric power steering, active suspension, anti-lock braking systems and radar-based advanced driver assistance systems (ADAS).

The MCU is part of the chipmaker's SafeAssure program (www.freescale.com/SafeAssure). It includes also sensors and analog ICs as well as support for functional safety application design. The program is intended to help system developers achieving more easily compliance with functional safety standards such as ISO 26262 and IEC 61508.

A similar program has been introduced by Texas Instruments (www.ti.com). The SafeTI system design packages for functional safety support the standards such as ISO 26262, IEC 60730 (home appliances), and IEC 61508. TI's Hercules family of MCUs is designed for safety applications, but has not been yet certified by an independent authority. Some of these components feature on-chip CAN modules. There are chipsets specifically suitable for motion control applications requiring compliancy to IEC 61508.

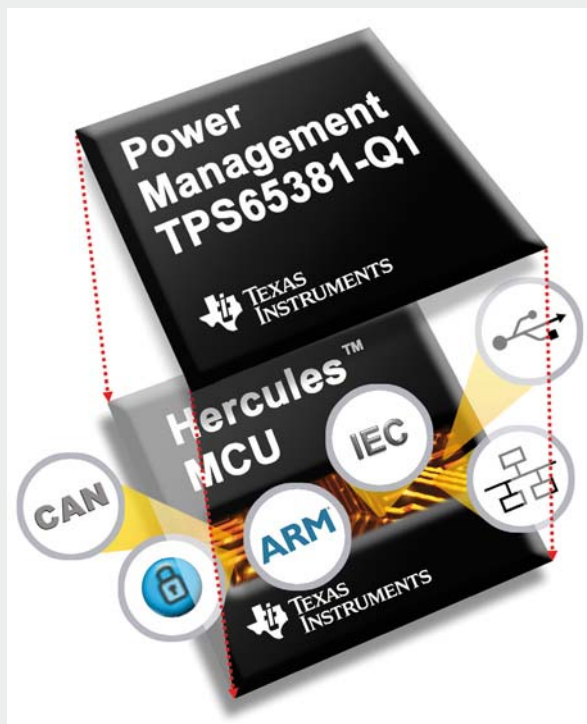
According to the ISO standard, functional safety is the absence of unreasonable risk

due to hazards caused by the malfunction of electrical/electronic systems. ISO 26262 targets complete automotive systems and consists of 10 parts, including clauses for hardware, software, their integration and the development and production processes.

Rainer Faller (Exida) said: "The certificate for Freescale's MCU is issued based on a successful assessment of the product design and applied development and production processes against all requirements and work product definitions of ISO 26262 identified as applicable to this micro-controller part. Freescale has done an excellent job with this product."



Continuation desired
Just a couple of months ago, the VDI decided to organize the 1st conference on electronics in mobile machinery. Initiated by Claas, a manufacturer of agriculture trucks and harvesters, and Putzmeister, producer of truck-mounted concrete pumps, as well as some suppliers (e.g. Hydac), the event was rather successful. Many participants appreciated the know-how exchange and the direct talks to engineers from other application fields. Dr. Wolfgang Runge, one of the conferences' mentors, thanked the sponsors and the speakers to make this event happen. "It was just a few month from the idea to the event." No doubt, a follow-up conference on electronics in mobile machinery is desired.



Besides Putzmeister, Liebherr and Wirtgen reported about their strategies to develop electronic control systems for construction machines. Interesting is that both mobile machinery industries develop increasingly the electronic control systems by means of the V-model as the automotive industry is

doing. Vector presented its software tool chain for both industries supporting the specific higher-layer protocols (CANopen, Isobus, and J1939).

The three conferences were accompanied by an exhibition, participated by more than 30 companies. Jetter and TTTech exhibited their control-

ler families for mobile machines with CAN connectivity. Hydac presented its CAN connectable hydraulic and sensor devices. Atmel, Bosch, and Infineon informed about their CAN semiconductor portfolios. Dspace, Etas, and Vector showed their well-known development and testing tools. Holger Zeltwanger

Isobus testing with implement and remaining bus simulations

Alexander Ostermüller, Peter Fellmeth

Authors



Alexander Ostermüller
Test engineer
John Deere European
Technology Innovation
Center (ETIC)
Strassburger Allee 3
DE-67657 Kaiserslautern
Tel.: +49-631-36191-0
ostermuelleralexander
@johndeere.com



Peter Fellmeth
Product manager
Vector Informatik GmbH
Ingersheimer Str. 24
DE-70499 Stuttgart
Tel.: +49-711-80670-0
peter.fellmeth
@vector.com

Links

www.deere.com
www.vector.com



The tractor is a multi-talented field machine due to its ability to interact with different implements. Modern automated agriculture solutions require support of such functions as variable spread quantities for seeds and documentation of the work performed on the field. It must be possible to connect any of a wide variety of implements to the tractor and have the tractor's electronics 'understand' it. The Isobus (a CAN-based protocol for agricultural machines defined in ISO 11783) was created so that tractors, implements and operator terminals could exchange data between each other. To ensure interoperability of devices from different manufacturers, extensive tests are required for tractor and implement producers.

Precision farming

Precision farming and the integration of intelligent

technologies in machines and agricultural electronics represent a focal point at John Deere's ETIC. The goal of precision farming is to attain the highest yield and economy by optimal use of available resources such as machines, seed stock, fertilizers, fuel, time, etc. The farmer takes the parameters of the planned field operations on the farm computer and uploads them to the operator's terminal in the tractor by a memory card or USB stick, or in the future via WLAN. Telematics and satellite navigation also make important contributions in combination with steering and track guidance systems as well as section control. The result is a seamless application of seed stock and fertilizers. At the same time, the technology provides for minimal overlaps on wedge-shaped fields and saves raw materials at field borders. Implements with section con-

trol are subdivided into multiple sections, which can be activated or deactivated independently of one another. Since all activities are logged, movements of the tractor during which the implement either protrudes beyond field boundaries or overlaps already covered areas result in automatic deactivation of the relevant sections.

Task Controller

The Isobus operator terminal is a user control and display system as well as a minicomputer on which multiple applications run simultaneously. Such an application is the Task Controller, which is specified in ISO 11783-10. It serves as a documentation and control system with an interface to the Farm Management System via the TaskData.xml file. In the John Deere GreenStar 2630 display, the Task Controller represents an inter- ▶

SIL 3 CANOPEN SAFETY



**Safe Single and Multiturn
Absolute Position Measurement
with CANopen Safety Interface**

Compliant with New Machine Directive
EN2006/42/EC

Highest Safety Standards
with SIL 3 EN/IEC 62061, Cat.4
and PL e EN ISO 13849-1

Certified by TÜV Rheinland®

Redundant High Resolution
Optical Design up to 30 Bit

Customer Advantage:
No PLC Plausibility Check for
Position Value Needed

www.posital.eu

POSITAL GmbH
Carlwerkstrasse 13c, 51063 Koeln, Germany
T +49 (0)221-96213-0, F +49 (0)221-96213-20

FRABA Inc.
1800 East State Street, Suite 148 Hamilton, NJ 08609, USA
T +1-609-750-8705, F +1-609-750-8703

FRABA Pte. Ltd.
8 Temasek Boulevard, #42-10 Suntec Tower Three
Singapore 038988, Singapore
T +65-6829-2348, F +65-6829-2121



NEUER FREIRAUM

Energy 1500 W digital Primärschaltregler

EINSATZBEREICHE

- Automatisierungs- und Prüfabläufe
- Labortechnik

FÜR HOHEN LEISTUNGSBEDARF

- Spannungs-, Strom- und Leistungsregelung
- Alle Signale und Schnittstellen potentialgetrennt
- Standardmäßig mit RS 232, USB und CAN-Schnittstelle mit CANopen-Protokoll (CiA); LAN, IEEE optional
- Programmierbare Sicherheitsfunktionen
- Einfache Bedienung über Quick-Taste und Drehknopf
- Schnelle Umprogrammierung sowie Rückspisefähigkeit durch 300 W E-Last
- Integriertes Mikroprozessorsystem zur zentralen Verknüpfung aller Daten

Kniel macht den Unterschied.

KNIEL System-Electronic GmbH
D-76187 Karlsruhe · Tel. 0721 95920 · www.kniel.de

Agricultural specialist

John Deere is a company producing agricultural machines, construction machines, forestry machines and public utility equipment as well as machines for lawn, property and golf course maintenance. The company provides German subsidiaries in Zweibrücken, Mannheim and Bruchsal. In early 2010 the European Technology and Innovation Center (ETIC) in Kaiserslautern (Germany) was opened as well.

Introduction

The inter-system and inter-OEM compatibility of Isobus conformant devices lets farmers interconnect tractors and implements from different manufacturers in any desired combinations. As easy as this may seem from the user's perspective, the level of effort required in the device development side is high, especially in the testing phase. A look at John Deere shows that conventional industry methods for testing electronic components are now often running into their limits. An incomparably faster and more efficient means for attaining the desired goal is automatic test sequences with a simulated implement environment.

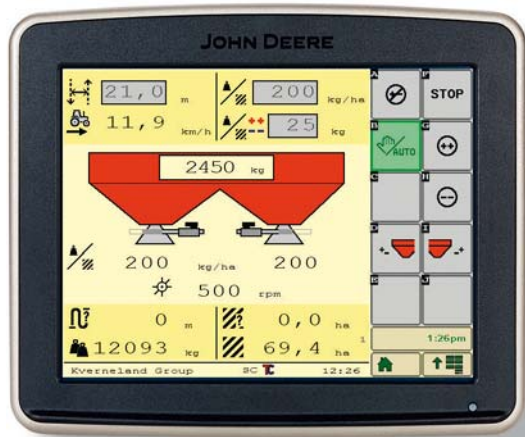


Figure 1: John Deere Isobus operator terminal with the Kverneland fertilizer spreader operating interface (John Deere)

face between the documentation system and an Isobus implement. The first time it is connected, the Task Controller loads a "Device Description File" from the implement's job computer. This file contains information necessary for the Task Controller, such as the implement's working width, type of mount to the tractor and number of switchable sections with as-

sociated element numbers, if it is an implement with section control. The implement may be operated via the tractor's operator terminal. The Task Controller has to master the entire bandwidth of possible implement device configurations to work properly with Isobus implements available on the market. Every work machine operates differently than another

and uses a different combination of Task Controller functions. For test purposes, producers exchange special hardware boxes, in which the electronic functionality of their implement is represented. To the chagrin of test engineers, aside from the ECU hardware and software contained in the boxes, they very seldom include all of the components needed to conduct a comprehensive functional test of the device logic.

More efficient test method

The ETIC employees were former also using test boxes and real devices of various implement producers to test the functionality and compatibility of their Task Controller. The test boxes are not standardized with regard to their layout or handling. Each company follows a different operating philosophy, and some boxes are pure simulations, while others largely match the real electronics. Before test personnel can perform their work, they must first study many different user manuals to gain familiarity with the virtual control elements and functions.

This approach motivated the engineers to seek a more efficient test method. They found the solution in CANoe.ISO11783. It is a development, test and simulation tool from Vector with Isobus conformity from the product development to the test phase and maintenance. The Isobus communication structures may be analyzed, visualized and prepared. The "Virtual Terminal" function may be used to simulate different display types, resolutions or black/white settings. The "Interactive Task Controller" function lets users load a device description from any real Isobus machine, or may be used to verify simulators before they are used for testing.

Test engineers made use of the tool's simulation

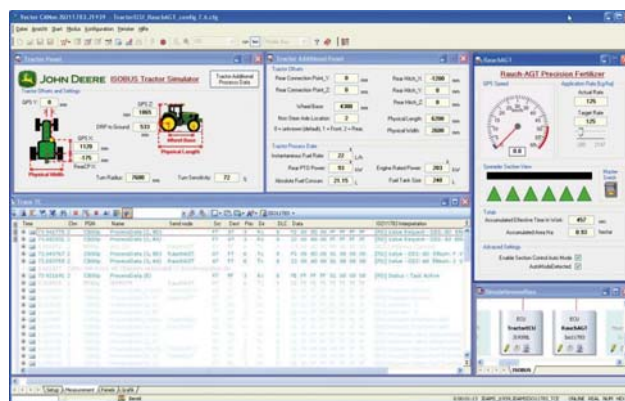


Figure 2: Simulation of tractor and fertilizer spreader (John Deere)

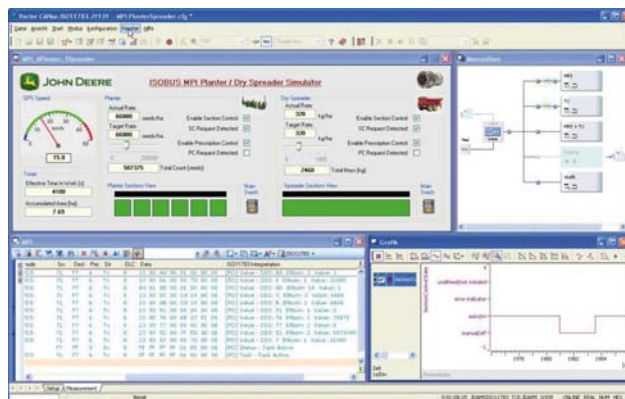


Figure 3: Support of an Isobus Multiple Product Implement by the Task Controller via a simulation (John Deere)

capabilities in order to be independent from implement producers. The tool may simulate individual ECUs as well as entire networks (remaining bus simulation). For defining automated and recurring tests the CANoe's integrated "Test Feature Set" is a useful feature. The system may act as either the Test Master or be inserted into existing test environments. Interfaces such as COM or .NET are available for control and communication with other tools.

For section control simulations it was possible to vary the type and sizes of working machines e.g. to check whether the Task Controller could handle 16 instead of 8 sections. Implements may also be defined whose sections are not strictly adjacent. Since the tool completely represents the Isobus standard, a higher level of test coverage in a shorter amount of time was attained. This was helpful in application situations with unsupported or just partially supported functionality by the hardware boxes. Such situations include tests of driving speed control, checking for correct handshakes or simulation of errors, e.g. when an implement does not signal its readiness for section control.

The tool is also used for the in-house development of ECUs. For testing, the real tractor hardware may be used or simulated. Users may toggle between different variants if multiple versions of a Task Controller need to be tested. The simulation configurations may be exchanged between company's departments via the intranet or by e-mail.

Covering future requirements

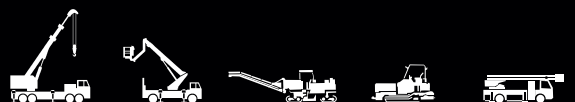
Tool's multi-bus capability enables displaying and interpretation of Isobus and J1939 messages in a Trace Window. It covers the Isobus functionality at the lat-

est revision level. Using the tool, John Deere has the ability to test extended Task Controller functions and also to simulate the counterpart device. Interesting in this context is the Isobus multiple-product implement simulator. A multiple-product implement might be a corn sowing machine with under-root fertilization. It enables simultaneous sowing and spreading of solid fertilizer. One of the benefits, besides time-savings, is reduced soil erosion, because the tractor only drives across the field once instead of multiple times. At the time of testing in early 2011, there was still no implement producer that offered such Isobus machines on the market. Therefore, it was only possible to have the Task Controller support for such machines in a simulation. From the perspective of John Deere employees, it would be desirable if manufacturers would exchange their CANoe simulations instead of the black boxes. The fear that this would somehow reveal internal know-how is unfounded, since it is possible to share the compiled simulations without the source, thereby preserving internal know-how. ◀

The innovative Safety Controller

**bauma
2013**

www.intercontrol.de
info@intercontrol.de
Tel. +49 911 9522-851



Controller for mobile machinery

Arto Orava

Author

Arto Orava
Research Manager
Epec Oy
Tiedekatu
FI-60100 Seinäjoki
Tel.: +358-20-7608-111
Fax: +358-20-7608-110
techsupport@epec.fi

Link

www.epec.fi

Introduction

Embedded systems and software technologies are enablers for innovations in the heavy machinery industry.

Time to market and keeping to schedule are important for successful machine automation projects. All stakeholders have their own requirements. Sales and product management are concerned about competitive product offering. Project managers and system engineers have pressure to keep to schedule guaranteeing high quality results. For production, the supplier should keep component delivery schedules year after year and make continuous quality improvements. After-sales want to have long-term availability of components to guarantee spare parts for the entire machine life cycle. For the supplier, it is not about having micro-controllers or ICs (integrated circuits) available, the whole software ecosystem must be supported. To summarize, machine manufacturers expect a high level of commitment from their key partners.

The production batches for mobile machinery industry are typically quite small. Sometimes only a couple of machines of a certain model are produced before next modifications. Obviously, the flexibility of the machine control system is crucial for such a case. Changes are also typical for serial production models to carry out continuous improvements and implement variants for emerging customer needs. Investments towards the development of a machine control system can't be thrown aside even in a case of big changes such as introducing a new automatic gearbox system to the machine. Flexible I/O interface of control units and higher-level CAN protocols, especially CANopen and J1939, are the key technologies to open a selection of building blocks that machine manufacturers can exploit. Epec 5000 product family is designed for machine control applications in different industrial segments, such as construction machines, mining machines, agricultural applications and heavy commercial vehicles. The robust mechanical construction of the platform can tolerate harsh operating environments that expose electronics to high mechanical shocks and vibration, temperature variation, dust, water and aggressive chemicals.

The size of application software and the number of parameters per control unit has been continuously growing in the course of system development. This



Figure 1: Company's control units in use

has resulted in a need for increased performance to keep the application cycle time within specified limits. Epec 5050 control unit targets these applications by introducing a 32-bit microcontroller running at 128 MHz clock frequency. Advanced control algorithms benefit from a floating-point unit that further speeds up the program execution. Moreover, a dedicated hardware unit provides flexible signal conditioning of pulse encoders with a minimal burden to the main CPU, thus releasing processing time for the application software. The real operating environment may introduce unexpected degradation of performance if these issues are not addressed during development of embedded firmware architecture. For example, high busload on several CAN networks may lead to a dramatic growth of the application cycle time for certain approaches.

Another consequence related to large applications is the need for increased memory space. The standard application size of Epec 5050 is up to 1 MiB and can be further expanded. Non-volatile RAM (NVRAM) is a suitable solution for saving of information

that needs to be retained over long power outages. Epec 5050 is equipped with a 512-KiB NVRAM for storing machine parameters or log files.

It is not enough to have sufficient hardware to make the physical implementation of the system. The tools must provide efficient means for system level design, control algorithm development, optimization and verification. The manufacturer introduced the Multitool system design and configuration tool. Due to an increased level of system distribution, the number of CAN-connected devices in machines is higher than ever. For different machine layouts and control system architectures, it may be feasible to use several CAN-segments that have dedicated protocols and bit-rates. For system integration, seamless compatibility for CANopen-protocols is a must and therefore in the center of the design. The Multitool provides interfaces to select preferred programmable control units to the system and to create CANopen object dictionaries (ODs) for these devices. Furthermore, third party CANopen devices, such as sensors, may be add- ▶



www.port.de

Professionals for Industrial Communication

ed to the control system by importing EDS (electronic data sheet) or DCF (device configuration file) files from the device manufacturer to the Multitool project.

The Epec 5000 family was designed to meet different control system architectures and increased system distribution. Epec 5050 provides four CAN interfaces. Each of these connections can use either CANopen or J1939 protocol. The control unit is suitable for centralized and distributed system architectures. Application programming is done according to the IEC 61131-3 standard by using Codesys. The system and PLC (programmable logic controller) configurations can be exported from Multitool and used as a project-specific code template in Codesys. This saves lot of work and reduces human errors compared to having to repeat many settings manually. A manual is provided to support product-specific questions for programming the device. The control unit is equipped with an Ethernet interface to speed up program downloading. Because Ethernet can be used as a Codesys interface, online debugging of applications does not introduce any additional communication to the CAN network. On the other hand, the programming and Codesys interface are also provided via CAN network.

To enable system developers to select the best tools for access to the communication system, Multitool generates CAN databases to export data structures to third party analyzing tools. Thus the system settings can be re-used in order to analyze, optimize and verify the control system's performance.

The 5050 control unit is equipped with 65 software-configurable I/O pins that have multi-purpose functionality while the total number on pins is 105. The compact size of the enclosure with respect to the functionality has been a design requirement to address limited assembly space in machines. 28 PWM outputs, switchable 5-V and 10-V supply voltages for sensors and configurable inputs are available. The control units operate with sensors and actuators from different manufacturers, thus providing more choices for system integration.

The company has also introduced a set of function libraries in order to simplify the creation of projects. By re-using these components and the advantages provided by the complete development environment, machine manufacturers and system integrators can benefit from a faster time to market for their innovations.



port provides to you a faster **Time-to-Market** with powerful DesignTools and solid and mature Protocol Stacks

port connects Industrial Worlds
reliable – fast – worldwide

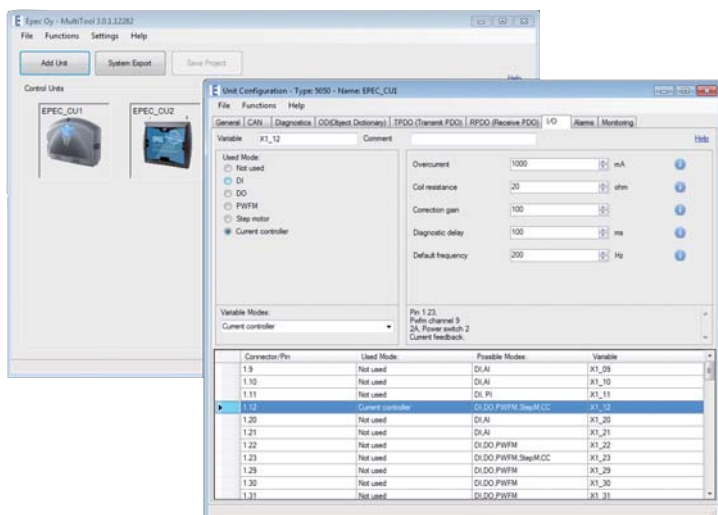


Figure 2: Multitool design and configuration tool



Contact: port GmbH
 Regensburger Str. 7b
 GERMANY – 06132 Halle/Saale
 +49 345 / 7 77 55 0
 +49 345 / 7 77 55 20
 service@port.de
 www.port.de

CANopen and J1939 sensors for agricultural technology

Thomas Hensler

Author

Thomas Hensler
Product Manager for
Inductive Sensor Systems
Pepperl + Fuchs GmbH
Factory Automation
Division
Lilienthalstr. 200
DE-68307 Mannheim
Tel.: +49-621-776-0
Fax: +49-621-776-1165
info@de.pepperl-
fuchs.com

Link

www.pepperl-fuchs.com



Figure 1: Field sprayer

Just as with commercial vehicles, agricultural machinery is benefiting from the capabilities of modern automation technology. Among the tasks, sensors play a central role in measuring inclination angles, detecting terrain type and controlling vehicles. Following the current trend towards non-contact, wear-free operating principles, Pepperl+Fuchs (Germany) develops capacitive, inductive, ultrasonic and other sensors designed for the requirements of agricultural engineering. Terms such as “smart farming” and “precision farming” sum it up. Tractors and attachments are becoming equipped with on-board computers and electronic control devices that enable the ma-

chines to optimize processes in the agricultural field. However, this is only possible if the sensors consistently deliver sufficient and current information about machine status and field conditions.

Mechanical and electrical properties of agricultural sensors differ from their counterparts in factory automation. Machines are exposed to dirt, moisture, fuel, hydraulic oil, road salt, fertilizers and pesticides on a daily basis. Only stainless steel designs are capable of meeting the requirements for chemical resistance. Mechanical robustness and resilience are also required in order to withstand vibration and severe shock.

In addition to the analog current and voltage in-

terfaces, standard interfaces using such protocols as CANopen and J1939 are also required. Vehicles cannot travel on public roads in Europe without e1 approval. From an electromechanical perspective, connection types must be adaptable to the relevant standards and manufacturer’s specifications. ISO 14982 contains information on the basic requirements specified for agricultural and forestry machinery.

Manufacturer’s range of sensors for agricultural technology incorporates the key technology types required to solve the detection tasks in agricultural applications. The sensors have a smooth and robust housing suitable for use under harsh conditions in outdoor ▶

environments. Furthermore, they satisfy the necessary criteria for electromagnetic compatibility (EMC) and offer a degree of noise immunity (100 V/m) that exceeds the minimum required values.

Inclination and acceleration sensors

In view of the increased size and complexity of agricultural machinery and the trend towards automatic drive systems, monitoring the inclination angle of machinery has become important. F99 series inclination sensors are suited to continually monitor and level vehicles, attachments, driver's cabs, etc. The sensors detect the inclination angle between 0° and 360° at resolutions of lower than 0,1° and are available in a one- or two-channel design. On request, the measuring ranges and outputs can be configured prior to delivery. In addition to models with 4-mA to 20-mA current interface, 0-V to 5-V voltage interface and CANopen network connection, the inclination sensor is available with a J1939 interface. The sensor fulfills IP68 and IP69K degree of protection and can be mounted directly to the vehicle using the sensor's integrated mounting design. Acceleration sensors from the same series are similar to the inclination sensor and detect short-term dynamic influences and forces on the vehicles and attachments.

For distance and load measurement

Ultrasonic sensors generate sound waves and have an averaging function. These are used for measuring distances on uneven surfaces, such as farmland, and the fill level of fluids and trailers, warehouses or silos containing seeds or harvested goods. On guidance systems that use furrows or grooves as

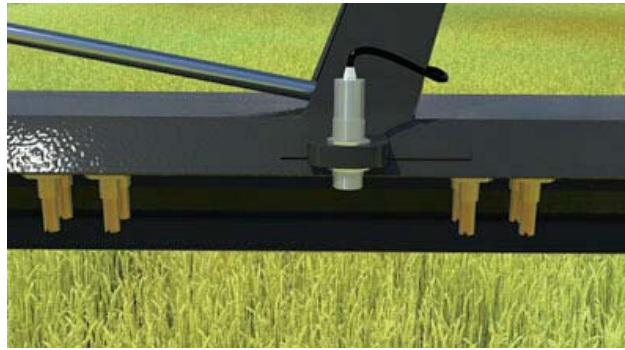


Figure 2: Ultrasonic sensors monitor the spraying arms to maintain a constant distance between the nozzles and the ground and ensure that fertilizer is spread evenly over fields

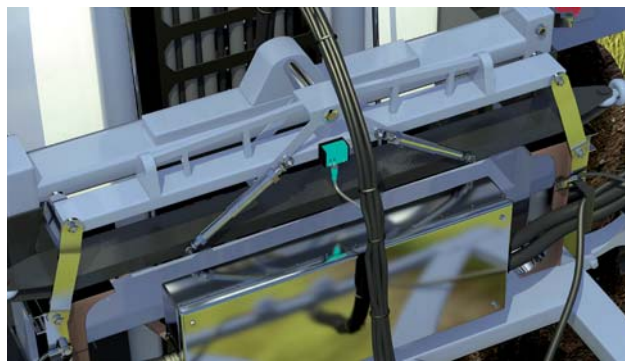


Figure 3: Inclination sensors monitor the level of the sprayer boom on a field sprayer



Figure 4: The F99 inclination sensor with CANopen or J1939 interface

a reference point, the generated signal is more accurate than signals generated by other technologies such as GPS. Ultrasonic systems are insensitive to soiling and therefore have the edge over camera systems, whose lenses present problems in dirty environments.

On field sprayers with large, extended spraying arms, ultrasonic sensors help keep the nozzles at a constant distance from the ground without using mechanical devices and ensure that fertilizer is spread evenly over fields. A ground distance monitoring system protects the spraying arms connected to the vehicle from damage.

The UMC3000 metal face sensor is just one example from the large selection of ultrasonic sensors. The sensor has a stainless steel housing and operates without a separate receiver module. It has a diameter of 30 mm and has a metal transducer on the front.

Capacitive and inductive sensors

Operator panels on agricultural machinery are often fitted with joysticks for controlling forks or attachments. A capacitive sensor integrated in the joystick tells the on-board electronics if the operator is actually moving the joystick. If the

operator is not touching the joystick, the engine speed and hydraulic pressure are reduced to save fuel, and safety functions, such as brakes and interlocks, are activated when necessary.

Inductive sensors are used in numerous agricultural applications. Cylindrical sensors with an M12 or M18 threaded metal housing are substitute for mechanical switches. They detect the presence of metallic machine components and the status of flaps, conveyors, harvesters and other components. The PMI, F90, F110 and F130 non-contact positioning systems also function according to the inductive principle and are used to detect rotation angles on steering systems and measure linear movements and paths on hydraulic systems.

The manufacturer offers a number of further sensor systems for agricultural technology to achieve "precision farming", e.g. RFID (radio frequency identification) solutions for identification tasks, heavy-duty rotary encoders, safety rotary encoders and vision sensors in a solid metal housing. To make it easier for machine manufacturers to integrate agricultural sensors in their products, the company offers a selection of connector solutions that can be adapted to customer requirements. These solutions support the standards of manufacturers such as Deutsch Industrial, TE Connectivity, Delphi, JST, Lear, ITT and Molex. Sending connectors and cables for separate assembly is no longer necessary. This allows immediate commissioning of the devices. ◀

Energy saving in automotive electronics architectures

Thomas Liebetrau, Ursula Kelling, Tobias Otter, Magnus Hell

Authors

Thomas Liebetrau
 Ursula Kelling
 Tobias Otter
 Magnus Hell
 Infineon Technologies AG
 Am Campeon 1-12
 DE-85579 Neubiberg
 Tel.: +49-89-234-0
 Fax: +49-89-234-0
 support@infineon.com

Link

www.infineon.com

Abstract

Most of the electronic functionality is not in constant use while the passenger vehicle is operational. Therefore it is obvious that either entire ECUs (electronic control units) or some functionality within one ECU can be deactivated temporarily. Partial networking introduces partially deactivated nodes into given electronics networks. This functionality requires transceiver devices decoupling a node from an active bus with selective wake capability. Communication and error management of the entire network needs to be adapted to this new situation. ECU degradation (enables an Autosar stack to save power) and pretended networking (assists network operations to continue to run) are smoother methods of managing temporarily deactivated nodes.

Bus systems in current vehicles do not support partial deactivation of ECUs combined with a selective wake while communication is running. All nodes are woken simultaneously when communication has been activated by a single node. ISO 11898-5 specifies the wake-capable high-speed physical layer for the CAN network. The specific low-cost option of CAN defined by General Motors (GMLAN, Single Wire CAN physical layer [3]) supports selective sleep (one or several sleeping nodes during active bus communication), but only allows global wake based on specific bus voltage level. LIN (Local Interconnect Network),

defined by a consortium starting in 2000, has been early designed with a global wake capability. Flexray also supports global wake, which is used to initialize a Flexray cluster. Separate wake of nodes (selective wake) is not supported in these bus systems.

Use of Ethernet should heavily grow in vehicle electronics within the next years. Ethernet already implements functionality to selectively wake nodes, but the implementation of this Wake-on-LAN feature consumes more energy than it is applicable in automotive environment.

Carmakers today demand the capability to selectively wake sleeping

nodes on a bus during active communication. A global wake feature is not sufficient. The majority of network nodes today are CAN nodes; therefore the biggest savings can be expected for CAN networks.

Partial networking principle

German car manufacturers have discussed partial networking since 2008. The basic idea is to independently switch single or multiple nodes within a network into current saving mode called standby or sleep mode (selective sleep) and be able to wake those nodes up on pre-defined wake CAN messages (selective wake). ▶

Bus System	Maximum Data Rate	Used Data Rate (Automotive)	Industry Standard OEM Standard	Physical Layer	Wakeup Capability	Remark
CAN	1 MBit/s (High Speed CAN)	500 kBit/s	ISO 11898-1 ISO 11898-2/5 www.iso.org	Unshielded Twisted Pair (UTP)	Active Bus (Global Wake)	Dominating CAN option
	125 kBit/s (Fault Tolerant CAN)	125 kBit/s	ISO 11898-1 ISO 11898-3 www.iso.org	UTP	Active Bus (Global Wake)	Currently Replaced by High-Speed CAN
	83.33 kBit/s (Single Wire CAN)	33.33 kBit/s	GM LAN (General Motors Local Area Network)	Single Wire	Higher Supply Voltage Level (Global Wake)	Defined by General Motors; No ISO Standard
LIN	20 kBit/s	19.2 kBit/s	LIN Consortium www.lin-subbus.org	Single Wire	Active Bus (Global Wake)	Low Cost Bus, Broad Usage
SAE J2602	10.4 kBit/s	10.4 kBit/s	SAE J2602 www.sae.org	Single Wire	Active Bus (Global Wake)	Based on LIN, Deviations on Data Link Layer
FlexRay	10 MBit/s	10 MBit/s 5 MBit/s 2.5 MBit/s	FlexRay Consortium www.flexray.com	UTP	Active Bus (Global Wake)	Usage in Real Time Systems (e.g. Chassis Control)
MOST	150 MBit/s	25 MBit/s 50 MBit/s 150 MBit/s	MOST Cooperation www.mostcooperation.com	Fibre Optical or UTP (MOST-50 only)	-	Focused on Multi-media Applications
Ethernet	Up to 10 GBit/s (40+100 GBit/s in definition)	100 MBit/s 1 GBit/s aim	IEEE 802.3 www.ieee.org	STP,UTP,Coax, Fibre Optical	Wake-on-LAN IEEE 802.3az	Industry Standard, first Usage in Vehicles

Table 1: Overview of vehicle networks with wake capability



CAN in Automation

CANopen® conformance test tool

- ▶ Test your CANopen implementation
- ▶ Assure the interoperability between CANopen devices
- ▶ Pre-test your devices in advance to device certification at CiA



For more details please contact the CiA office at conformance@can-cia.org

www.can-cia.org

CAN | CANopen® | J1939

for QNX® and PREEMPT_RT Linux

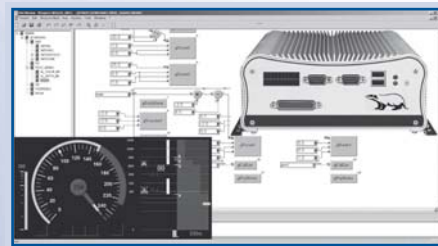
the stable and reliable real-time platform for embedded & distributed systems

DACHS®

Distributed Automation Control System

Standard DACHS® products for CAN

- CAN Layer2, CANopen, and J1939 in real-time
- high performance drivers and APIs
- CANopen stack with sources
- IEC 61131-3 / IEC 61499 programming
- DACHSVIEW-SDL



supported boards:

PC/104, PC/104-Plus, PCI, PCIe, ISA, SoCs

supported CAN controllers:

SJA 1000, i82527 or Bosch CC770, msCAN, HECC, TouCAN, etc. for x86, PPC, ARM9, etc.

OEM solutions and adaption for OEM platforms

CONSULTING & ENGINEERING



+49 (0)64 31-52 93 66 · info@steinhoff-automation.com
www.steinhoff-automation.com · www.dachs.info

FLEXIBLE | RELIABLE | INNOVATIVE | EMBEDDED
PC-BASED | REAL-TIME | FIELDBUSES

DACHS® Product Suite, support worldwide, consulting & engineering
DACHS is a registered trademark of Steinhoff A. All other trademarks belong to their respected owners.

Motivation

Up to now, there has been no visible benefit for the customer in using car energy saving solutions. If the combustion engine is running, electrical energy has always been considered as a given resource. Engineers rather have concentrated on the lowest possible current consumption while the car is in rest. From 2020 onwards there will be a challenging threshold for CO₂ emissions with 95 g CO₂/km for passenger cars sold in Europe. Introduction of vehicles with electrical drive trains will accelerate the transition to energy efficient solutions. For this type of cars energy efficiency directly influences mileage; it turns into a visible benefit to the customer. Therefore, current consumption during car operation is increasingly moving into the focus of automotive engineers. Current methodologies for ECU current consumption, without consideration of load currents, could make energy savings of up to 50 % compared to the status quo today. German carmakers currently dominate these discussions [1], but it is certain that those measures will be implemented on a worldwide basis across the vehicle industry within a certain timeframe.

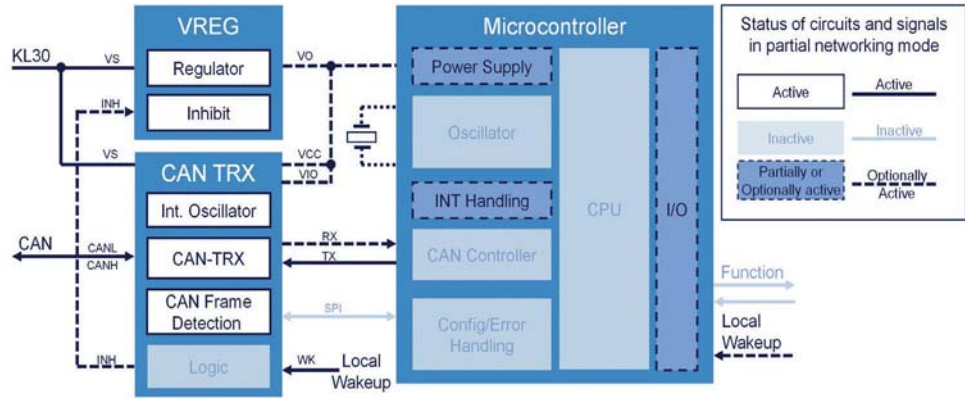


Figure 1: Basic principle of partial networking

Mid of 2010 the German car manufacturers founded a working group called SWITCH (selective wake-up interoperable transceivers for CAN high-speed networks) in order to define CAN transceivers with selective wake capability. The working group has provided a draft document (ISO 11898-6) specifying such transceivers to the ISO community. In addition, a supporting conformance test (ISO 11645-2) and a supplemental OEM requirement specification, similar to documents for existing transceiver solutions for CAN, LIN and Flexray, have been defined (see [6]).

During bus sleep the transceiver will wait for a 'wake-up pattern' (WUP), which can be part of one or more CAN frames. This mechanism had been already introduced in ISO 11898-5. As soon as bus traffic was detected, the device in selective wake mode autonomously scans CAN frames on the bus for a 'wake-up frame' (WUF) in order to switch the ECU back into the normal mode of operation. The microcontroller on the ECU could either be switched-off during selective wake mode (the assumed mode for most applications), or remain partially active.

When implementing one or more nodes, which could be deactivated while normal bus communication

is running, the possible effects on application software must be considered. If one ECU requires data from another ECU, which is in partial networking mode, it is essential to send a wake message (WUF) to that ECU before sending the information request. Therefore advanced network management needs to be implemented in order to manage sleeping ECUs to prevent malfunction within the network.

The Autosar community has been working on a concept dealing with this constraint. Called partial networking it will be the basis of ECU software for CAN nodes with selective wake capability. It is therefore limited to vehicles with Autosar software architecture.

Partial networking means partial deactivation of sub-nets within a given network. There is no intention to individually deactivate a single node, but clusters of ECUs simultaneously, in order to reduce the additional number of possible different vehicle states. The car manufacturers define these ECU clusters based on a common behavior in various driving situations; the partial networking wake scheme enables an individual wake of any cluster or even a combination of two or more clusters. This is seen as the only reasonable way to limit the verification effort of electronic networks dur-

ing vehicle development (see [2], [4]).

ECU degradation and pretended networking

The selective sleep/wake of ECU nodes does not cover the control of power consumption based on the dynamic requirements of functionality and performance. Operational ECU features are usually targeted to the maximum required performance. For an engine control unit for example, it covers functionality at the highest possible crankshaft speed. The required performance is reserved permanently but is only rarely needed. Sometimes peripheral functions on ECUs are deactivated while temporarily not in use, but the micro-controller is consuming energy while running in wait loops.

Observing solutions outside the automotive industry, the consumer electronics field (e.g. in smartphones, notebooks) already uses very intelligent systems involving microcontroller-/processor performance adaptation [7], which show that efficient, dynamic adaptation of current consumption to the needs of the application can be achieved. In vehicle electronics, there are important differences that need to be considered. Any efficiency feature must neither decrease the level of

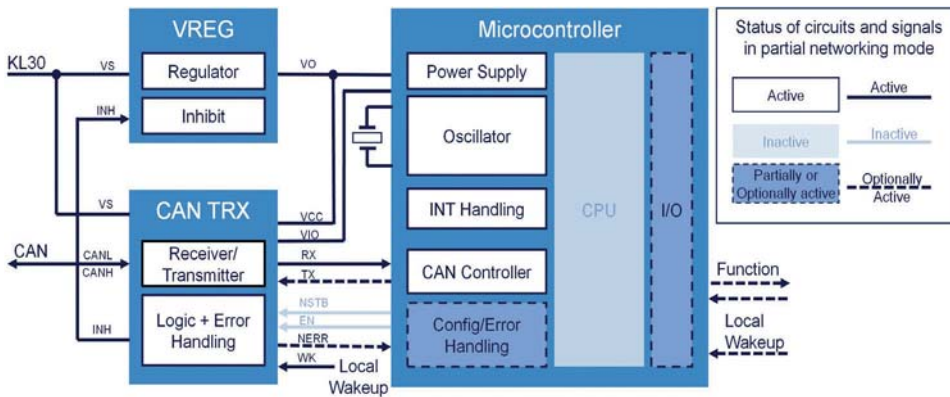


Figure 2: Basic principle of pretended networking

reliability, nor influence any ECU functionality, nor impact the response time to the customer. Vehicle safety requirements are also increasing. Energy saving techniques must not influence the interaction of the complex hardware/software system structure, and any impact to field failure rates must be prevented. As a result it is highly recommended to limit the number of device states with an easy-to-use structure of transitions between low power and normal modes.

The Autosar ECU degradation of functionality is applied only to the microcontroller. Certain functionality can be switched-off; low power states are possible in a single core as well as in multi-core devices for each CPU separately, including the main CPU. It must be certain that the operating system is running without any impact at all times.

Micro-controllers already offer various current saving modes, which are only rarely used in today's ECU designs. Since it is possible to switch-off parts of the peripheral units of the micro-controller while keeping the CAN controller alive, results are already substantial (see [7], [8]). Since early 2010, the Autosar community is working on the pretended networking concept using the measures defined in ECU degradation, but also enabling the network to re-

main running at the same time. These methods can also only be used in Autosar software architectures. Pretended networking can be used in networks where an ECU can switch into a self-determined low-power mode returning to normal operation dependent on received CAN frames or signals. This feature enables transparent behavior in a given network. An ECU can take action at any time and with a very low response time on incoming events and vehicle states. It does not require one special wake-up

frame. Additionally, cyclic transmission of predefined CAN messages is possible without using the microcontroller CPU. It is possible to integrate pretended networking in existing networks, for example in given car platforms, without affecting other nodes in the network. In summary, the basic advantage of pretended networking is that it supports the transparent migration of current saving ECUs into a given car platform [5]. However the absolute value of current saving is smaller compared to partial networking.

Implementation of a selective wake

The first implementation of a selective wake CAN transceiver from Infineon is the TLE9267 system basis chip. Figure 3 shows the block diagram of this IC developed for door control units. System basis chips (SBC) have been used for many years particularly in control units of the body electronics. In addition to the typical supply and communication functions (voltage regulator, watchdog, SPI, CAN and LIN transceiver), they often incorporate other, application-specific functions, such as high- and low-side drivers. To assure the required downward compatibility, Infineon offers an otherwise function and pin-compatible SBC with a CAN cell according to ISO 11898-5 (TLE9266). Both ICs provide the basis for further products of a new SBC generation and are currently (October 2012) in development. The derivatives within this family will be pin and software-compatible [9].

Overview of low-power modes

Particularly when using an SBC, distinctions are made between different power-saving states, which can be selected depending on the function of the control unit as well as however depending on the operating state of the vehicle. In each of the low power modes, the CAN bus allows the user, depending on the configuration, to use a selective wake either for an active bus with a 'wake up frame' (WUF) or, however, for an inactive bus, to use the wake-up function according to ISO 11898-5. To improve its disturbance immunity and to minimize incorrect waking on the bus due to spikes, a series of dominant levels have been defined for this in ISO 11898-6, otherwise known as the 'wake-up pattern' (WUP).

Sleep mode

In SBC sleep mode, the voltage regulator is deactivated, the micro-controller is no longer supplied, and waking can only be triggered via CAN or other waking sources in the SBC, e.g. monitor

inputs. If a wake-up is detected, the SBC activates the voltage controller, the micro-controller starts, re-initializes itself and proceeds to process the incoming CAN messages. In sleep mode, it is possible to achieve the lowest power consumption at the expense of a long wake-up time and highly restricted functionality.

Stop mode

In SBC stop mode, also referred to as standby mode by some manufacturers, the voltage supply of the micro-controller remains active, although the voltage regulator integrated in the SBC may only show a minimal current consumption of $<30 \mu A$. While the SBC is in stop mode, a corresponding low power mode can and must be set in the micro-controller so as to permit low current consumption. This makes it possible to connect further wake-up sources to the micro-controller, to use polling in the micro-controller and to realize a fast wake-up time.

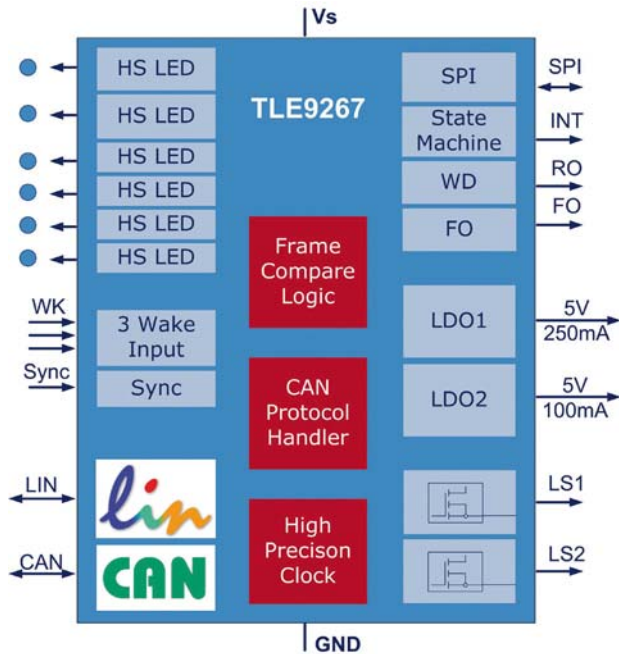


Figure 3: Block diagram of the TLE9267

Selective wake mode activation

For partial networking, individual nodes are deactivated or switched into a low power mode. This changeover is realized by means of a normal CAN message via a central control unit (power master or gateway) or also locally. Here, the formation of clusters is favored so as to switch multiple control units simultaneously into the low-power mode and also to wake these up again all together (see also [2], [4]).

When low-power mode is requested, the information must be available in the control unit regarding by which CAN message the node or nodes are to be woken up again, and which mask the nodes are to use for evaluating the CAN messages. Depending on the network architecture, this information is transferred once during the initialization/configuration of the network or each time partial networking mode is activated, e.g. via the power master.

The micro-controller in the corresponding ECU receives this information. To do this, it uses the protocol handler found in the micro-controller, the ISO data link layers and, if necessary,

the corresponding Autosar drivers. The transceiver is used in normal mode for the physical connection to the CAN bus. Once the micro-controller has received and processed the information, it configures the transceiver and/or the SBC by transferring the wake-up mask by SPI and, by reading back, ensures that the information has been transferred correctly.

As such, the requirements are satisfied for activating partial networking in the SBC and/or transceiver and for switching into low power mode. Once the micro-controller has delivered the corresponding SPI message, it switches itself off or goes into a low power mode. The changeover is critical, since no CAN wake-up message is allowed to be lost during the changeover. Consequently, the start machine is implemented in TLE9267 in such a way that the evaluation of the CAN messages can be carried out in parallel for a time by both the SBC and the micro-controller.

Processing of wake-up frames

Every incoming CAN frame is sampled by the CAN transceiver, is checked for framing errors and com-

pared with the mask. This requires a precise oscillator clock and the receiver section of a CAN protocol handler in addition to a logic that compares the received CAN message with a mask. Figure 5 shows a simplified block diagram of the implementation of a selective wake CAN cell. This block can be used in a standalone CAN transceiver, a system basis chip, and of course also in a larger system-on-chip.

Sampling with oscillator

Sampling is performed with a bit-time logic according to ISO 11898-1 that defines at which point the respective CAN bit is sampled and with which maximum jump displacement a phase error can be corrected. For a CAN bit-rate of 500 kbit/s, a sampling point of 80 % and a maximum jump displacement of 400 ns are recommended. The requirements on the oscillator result from the signal propagation delay in the CAN network including all parasitic effects

and the oscillator deviation of the transmitter. An active CAN node has a maximum oscillator tolerance of 0,5 %. A passive CAN node in selective wake mode permits a greater tolerance of the order of 1 %, since only receiving takes place during bus arbitration and nothing has to be sent. The first 65 % of the bit-time is reserved for network propagation delays including arbitration. The timing is schematically represented in Figure 6.

For active nodes, a quartz oscillator is typically used at the micro-controller. In selective wake mode, however, so as to keep the current consumption and costs low, an integrated RC oscillator is used in the transceiver and/or SBC. The particular challenge here involves balancing production fluctuations as well as temperature and long-term drifting. In addition, methods are available for calibrating the internal clock with the aid of the CAN data stream.

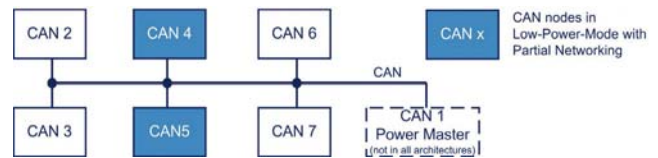


Figure 4: CAN network with partial networking and power master

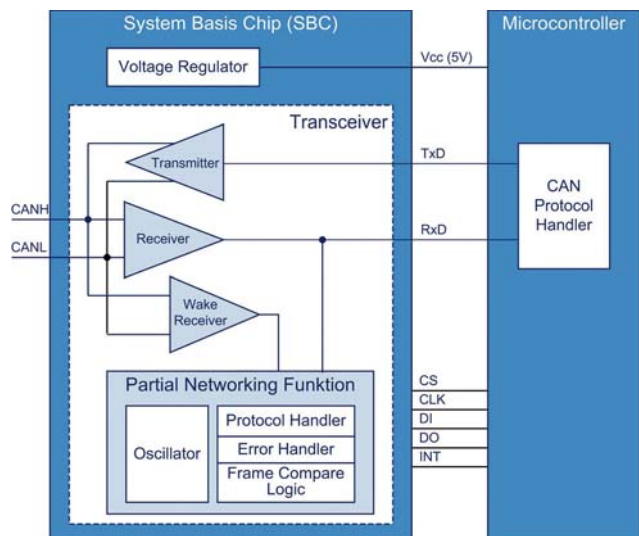


Figure 5: A simplified block diagram of a selective wake CAN transceiver cell

CAN Newsletter Online
Hardware + Software + Tools + Engineering

- ▶ Product and service news
- ▶ Brief news on product updates
- ▶ Brief application reports
- ▶ Dossiers and features
- ▶ Background information

Linked to CiA's Product Guides.
Integrated into CiA's website.
Complementing CAN Newsletter.
Associated to iCC proceedings.



For more details please contact the CiA office at
publications@can-cia.org

www.can-newsletter.org

Professional Solutions in
IEC 61131-3
CAN/CANopen
Ethernet POWERLINK

Customer Services

Consulting and Training

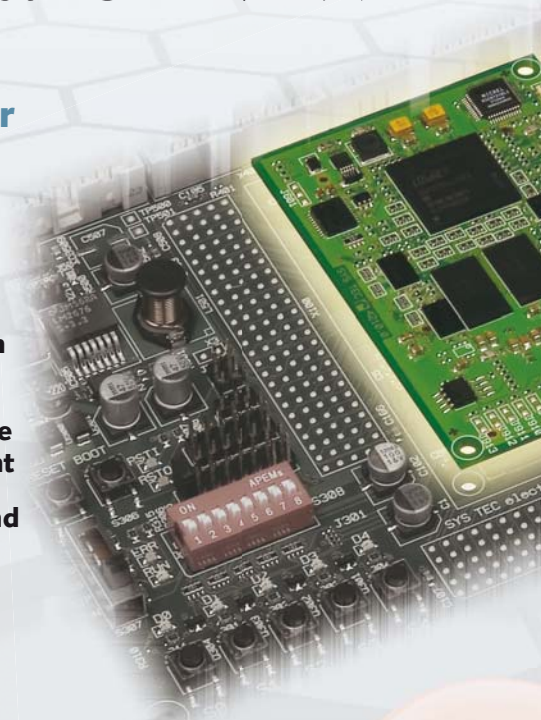
Project Specification

Hardware and Software Development

Assembly and Production

Prototyping

OEM Integration Services



Single Board Computers

Insert-ready 32-bit core modules with CANopen slave firmware and IEC 61131-3 PLC runtime kernel

Field Bus Protocol Stacks

CANopen protocol stack and tool chain
Ethernet POWERLINK protocol stack

CAN interfaces

for Ethernet and USB with 1 to 16 channels

Automation Components

CANopen I/O extension modules
IEC 61131-3 controls with CANopen manager

sysWORXX
Automation Series

PRODUCTS

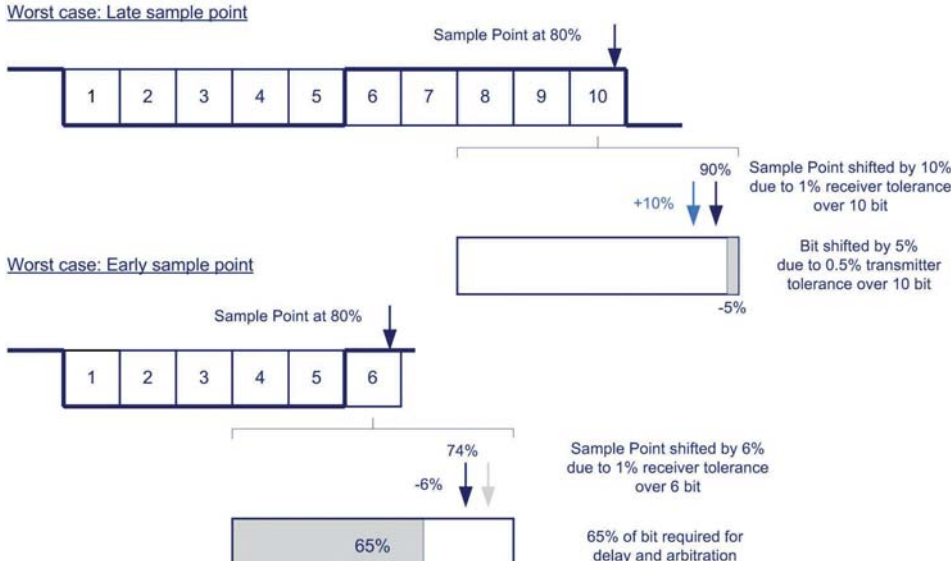


Figure 6: Timing of bit scanning

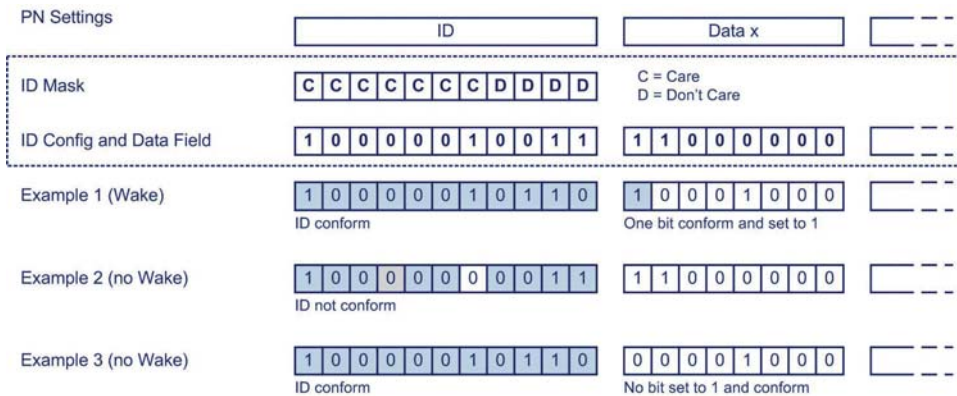


Figure 7: Basic principle masking of wake message

Troubleshooting

To prevent incorrect waking due to a disrupted CAN communication or that nodes can no longer be woken up, the CAN protocol handler incorporates an error detection facility in accordance with ISO 11898-1. This processes the errors Stuff Error, CRC Error and Form Error. Errors that occur downstream from the CRC delimiter are not processed. Incorrect CAN messages are not evaluated as wake-up messages, neither does any signaling of a detected error take place in the form of an error frame. Instead, an error counter is integrated that counts up the CAN errors detected and wakes up the local node in the event of a counter overflow. Accordingly, the micro-controller and/or control unit soft-

ware is given the opportunity to take over of the troubleshooting.

Comparison of the wake-up messages with the mask

Every incorrectly received CAN message is compared with the stored wake-up mask. If the criteria for the comparison are satisfied, the micro-controller is woken up by the SBC and/or transceiver. For the comparison, the CAN-ID, the DLC (data length) and the number of data bytes defined in the DLC are evaluated. For the CAN-ID, a mask (ID mask) and a comparative value (ID config) are used, the DLC must match the stored value. The data bytes are compared bit by bit, with a matching '1' at a bit position leading to a wake up. This method makes it pos-

sible to use one CAN-ID to group up to 64 CAN nodes correspondingly into clusters and to wake them.

Time-out function

To reduce the current consumption even further in parked vehicles and also have the ability to wake nodes selectively, a time-out function has been implemented. If selective wake is activated in a node, but the bus remains inactive for a long period of time (typically 1 s), the SBC and/or transceiver deactivates the selective wake function. As a result of activity at the CAN bus, this is however reactivated at the latest after five CAN frames and is able to evaluate CAN messages. In selective wake mode, biasing of the CAN line is also activated, that is, the CAN lines are kept at 2,5 V mean

voltage so as to prevent disturbances on the active CAN bus. In this mode, the node behaves as if it were an active node with a recessive output signal. In global wake mode with an inactive bus (detection of the WUP), biasing is deactivated, however. Figure 8 shows all the mode transitions with their respective conditions.

Implementation of pretended networking

ECU degradation includes different power measures to ensure power saving, but in essence it enables Autosar to introduce a power saving state. The ability to switch-off modules during the operation of an Autosar stack is now defined as a standard feature. The corresponding function also has free parameters for the integrator, enabling further module power saving functions. For example the free parameters implementations are enabled to include features such as clocking down a module, which is currently used, but that is not needed in full operation. This is the very first step for saving power.

ECU degradation also defines that single CPUs can be set to "Halt" mode (also referred to as "Idle"). Why single CPUs? Firstly, an ECU may not run only one application in the future. By using mechanisms initially intended for safety features, modules can be protected against unwanted access from other CPUs, therefore it becomes possible to partition one micro-controller among applications. With low power states and reduced operation, one CPU might be sufficient to run all remaining operations. Therefore this mechanism is essential for a power saving state.

The concept also includes 'switching runnables'. Even though runnables could be switched-off before ECU degrada-



VN1600 – The new Standard for Bus Interfaces

Flexible and cost-efficient: the new bus interfaces with USB interface for CAN, LIN, K-Line and J1708 are available!

Take advantage of these features:

- > Fully equipped interfaces with from 2 to 4 channels in compact design for any application
- > Flexible bus transceivers for CAN, LIN, J1708 or K-Line
- > Optimal performance for CANoe, CANalyzer and CANape or own applications with the integrated 400MHz CPU
- > Prepared for CAN buses with higher data rates (CAN FD) by reconfigurable FPGA hardware architecture
- > Fast flashing with hardware acceleration
- > Ideally suited for automotive temperature range with power supply via USB, also applicable with multichannel applications

The new VN1600 bus interfaces can be used as the optimal network interface in the laboratory, on the test bench, in the service shop or directly in the vehicle. The application areas range from simple bus analysis to diagnostics, calibration and flash programming tasks as well as complex remaining bus simulations.

► For more information: www.vector.com/vn1600interfaces

Ready for CAN FD
Get your free copy of the new
CAN reference chart:
www.vector.com/CANFD

Flexible, Cost-efficient Network Interfaces with USB Interface for CAN, LIN, K-Line, J1708 and IO

What is VN1600

The VN1600 interface family succeeds the market-proven USB CANcaseXL interface.

While the VN1610/VN1611 with 2 channels focuses on minimum size and weight, the VN1630/VN1640 with 4 channels is designed for flexibility and IO support.

The VN1600 family provides the best network interface for Vector tools such as CANoe, CANalyzer, CANape, Indigo, vFlash as well as customer applications; in the laboratory, at the test bench, at the service garage or in the vehicle.

The application areas range from simple bus analysis to complex remaining bus simulations, diagnostic, calibration and flash programming tasks. The product's multi-application support makes it possible to access multiple programs in parallel on one device and on the same channel.

Overview of Advantages

- > Bus transceiver with proven CAN/LIN/J1708-Piggies
- > Power supplied via USB, in 4-channel applications as well
- > Optimal performance for CANoe, CANalyzer, CANape or customer applications, with Multi-Application support
- > Prepared for CAN buses with higher data rates (CAN FD) by reconfigurable FPGA hardware architecture
- > Advanced LIN stress e.g. for LIN 2.1 conformance tests (VN1630/1640)
- > Synchronized channels with minimal latency times
- > K-Line support
- > CAPL on Board for CAN (VN1630/40)
- > Fast CAN flashing by a hardware-based flash routine implementation
- > Customer applications can be linked with the proven XL Driver Library

Analog/digital IO for VN1630/VN1640

- > Analog input: 1 channel, 0..18V, max. 32V, Ri>1M0hm, 10bit ADC, 1kSps
- > Digital inputs: 2 channels, Schmitt trigger, max. 32V, Vhigh≥2.7V, Vlow≤2.0V, Vhyst=0.7V, Ri>200k0hm, max. 1kHz
- > Digital output: 1 channel, open collector, max. 32V, max. 500mA, max. 1kHz
- > D-SUB9 socket with common IO GND

Functions

- > Flexible FPGA-based CAN and LIN implementations allow 100% bus load on all channels
- > Performing LIN 2.1 conformance tests with CANoe (VN1630/1640)
- > Fast baudrates are available: CAN (max. 2 Mbit/s), LIN (max. 330 Kbit/s)
- > The integrated IO functionality of the VN1630/40 makes it possible to synchronously acquire signals along with CAN/LIN messages and switch loads up to 500mA via a digital output
- > For weight and space savings, the VN1610/ VN1611/ VN1630 have integrated CAN High-Speed transceiver(s). The standard D-SUB9 connector now supports dual channels.

Technical Data

	VN1610	VN1611	VN1630	VN1640
Max. channels	2	2	4	4
Variable transceivers (Piggies)	-	-	2	4
Permanently installed transceivers	2 x CAN 1051cap	1 x LIN 7269cap 1 x CAN 1051cap	2 x CAN 1051cap	--
Channel combinations				
Fixed	2 x CAN	1 x LIN / K-Line 1 CAN	2 x CAN	--
Variable (Piggy: *mag/*cap)			0..2 x CAN 0..2 x LIN 0..2 x K-Line 0..2 x J1708	0..4 x CAN 0..4 x LIN 0..2 x K-Line 0..4 x J1708
No. of D-SUB connectors	1 (dual channel)		2 (dual channel)	4 (single channel)
Time stamp accuracy				
within one device	1 µs			
between multiple devices	30 µs			
with Sync cable	not possible		1 µs	
Baudrates	CAN up to 2 Mbit/s. LIN up to 330 kbit/s. With ST. min control in hardware for fast flashing (256Ch).			
Mean reaction time	300 µs			
Error frame / Remote frame	Bit-precise detection and generation			
Operating system req.	Windows XP/Vista (32 bit), Windows 7 (32 and 64 bit)			
PC interface	USB 2.0 High-speed, fully bus-powered, no external power supply			
Driver libraries	XL Driver Library			
Ambient temperature range	Operating: -40..+70 °C, Storage: -40..+85 °C			
Dimensions (L/W/H)	65mm x 42mm x 20mm		85mm x 106mm x 32mm	85mm x 106mm x 42mm
Weight	approx. 60g		approx. 210g	approx. 290g
Housing	Robust plastic housing		Highly robust aluminum housing	

*CAN FD support requires CANoe/CANalyzer 8.0SP3 or later. Contact Vector for a device driver.



VN1640 for 4 CAN/LIN Piggies

VN1630 with 2 CAN-HS and for 2 CAN/LIN Piggies

VN1611 with CAN-HS/LIN

VN1610 with 2 CAN-HS

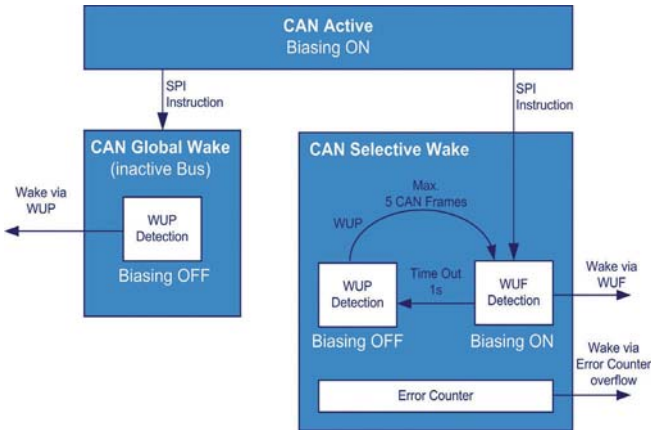


Figure 8: Selective wake mode diagram

tion, the influence on software was re-examined and also rechecked in terms of switching single CPUs into “Halt” mode. Even though each of these measures sounds simple, many side conditions had to be checked to enable operation of an Autosar stack. For non-Autosar systems, which are either already designed to incorporate power saving states or which are less complex, the described mechanisms should be easier to integrate. For systems with a similar complex environment, not designed for power saving, these measures are also advised for power saving, but integration may be difficult.

One measure was skipped during the definition phase of the ECU degradation definition. Central frequency scaling could enable ECUs to have two fixed points, one ECU full operation state, and one ECU

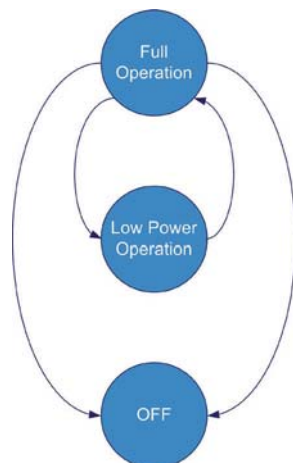


Figure 9: Power states of an ECU with ECU degradation

power saving state, with two different frequencies globally distributed to the whole system. As in current systems, bit-rates of all communication controllers need to be switched to a different value, as long as no additional clock for the communication part exists.

As yet, the fear to integrate this concept into Autosar has been too big so far. Even though on micro-controller families like the Aurix [10], central frequency scaling and stable bit-rates are supported. Central frequency scaling has the highest power saving potential, but having local frequency scaling on modules is a good first step.

Network management with pretended networking

Pretended networking had the following requirements as a starting point: Save power, no influence on network architecture and fast wake-up times. The power saving features have been moved to ECU degradation to avoid duplicate definition of the same mechanism. Therefore the disabling of modules and the definition of how to get into “Halt” mode are not part of the concept. Instead, the concept includes a description to enable pretended networking mode itself and the wake-up procedures.

The pretended networking approach is split into two levels. The first lev-

el applies the ECU degradation approach while pretended networking serves as the communication backpack. The second approach assumes that the micro-controller has two power domains. One power domain includes the communication modules and another that includes the CPU and the rest of the modules. Both concepts have in common that during the power saving state, communication shall continue. The communication itself shall run on a reduced catalogue and a set of wake-up sources shall be switched active. The wake-up sources are not necessarily hardware events, but could also be a set of hardware/software events. This allows for more complex wake-up masks, with for example special bits being set within the data segment or data length violations. Therefore a CPU wake-up does not necessarily mean that the complete software stack needs to be started, in case a wake-up event is declared invalid.

In level 1, where it is only necessary to leave the “Halt” mode, an extremely short wake-up time can be achieved. As the CAN module is running all the time, the actual messages are still buffered and can be transferred to higher soft-

ware layers. To enable the network management to run without waking the CPU up all the time, network management supervision is required. A timeout on certain CAN message objects is therefore used. The timer shall expire in case no network management message has been received for a certain time, to ensure the micro-controller is in bus sleep if no further network management is running. To avoid this timeout on other network ECUs, the network management of the ECU in pretended networking needs to continue running. Messages therefore need to be triggered also within pretended networking mode. An internal or external timer needs to trigger those messages to prevent any influence on the network.

In level 2, no CPU is available. As a result, all referenced operations including all wake-up source validation needs to be performed in hardware. With the main domain of the micro-controller shut off, the micro-controller wake-up time is dramatically increased. At wake-up, the complete software stack needs to be reloaded with the requirement of resetting the micro-controller, but communication modules shall be read out first. ▶

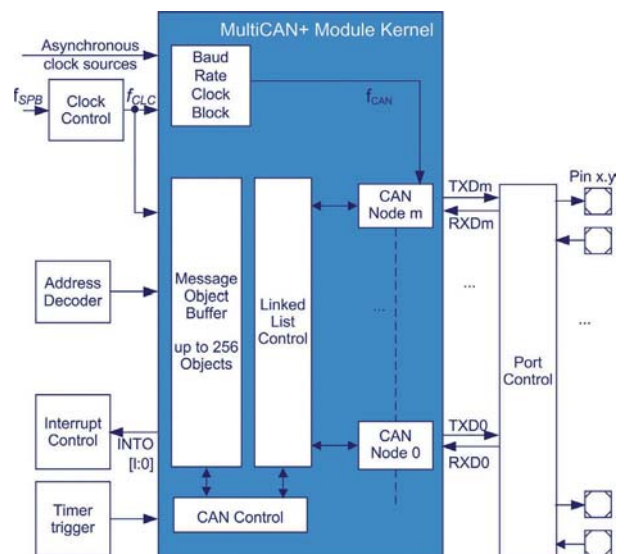


Figure 10: MultiCAN+ module block diagram

References (1)

[1] Frickenstein, Wilhelmi, Hudi, Michael, Tanneberger, Milke
New Automotive Standards 15th Int. Conference 'Advances in Automotive Electronics' · Ludwigsburg · 2011

[2] Scheer, Fuchs, Grzembra, Liebetau
Selektiver Teilnetzbetrieb und Clusterbildung – Erprobung unter realen Fahrbedingungen Elektronik im Kraftfahrzeug 2011 – 15. Internationaler Fachkongress des VDI VDI-Berichte 2132 · ISBN 978-3-18-092132-7 · VDI Verlag Düsseldorf · 2011

[3] GMW3089 - GMLAN
Single Wire CAN Physical & Data Link Layer Specification; General Motors Corporation

[4] Meyer, Esch, Linn
Teilnetzbetrieb – Abschaltung inaktiver Steuergeräte: Anwendung, Standardisierung und Absicherung Elektronik im Kraftfahrzeug 2011 – 15. Internationaler Fachkongress des VDI VDI-Berichte 2132 · ISBN 978-3-18-092132-7 · VDI Verlag Düsseldorf · 2011

[5] Speh, Dr. Wille
Pretended Networking - Migrationsfähiger Teilnetzbetrieb ATZ Elektronik 04/2012 (August 2012) page 264 ff.

[6] Butzkamm, Bollati
Partial Networking for CAN bus systems: Any saved gram CO₂/km is essential to meet stricter EU regulations 13th International CAN Conference · Hambach Castle · 2012

Infineon has opted to support level 1, which has been further developed in the definition of the Aurix family of products. The definition of pretended networking had a direct influence on the definition of Aurix CAN module. Multi-CAN+ is an evolution of the company's MultiCAN module. As with recent Multi-CAN implementation, this is now a module having two clock domains, but it includes the option to have separately configurable interrupt for each single message object, and the possi-

bility to overwrite message objects.

Some further improvements now support pretended networking. Network management (NM) timeout is introduced. For each node, one timeout is available, which allows multiple message objects to be connected to it. In case none of the selected message objects have received a message for the programmed maximum timer value, a timeout will occur and an interrupt will be issued. A similar mechanism is used for sending

NM messages. Three timers have been introduced. The timers are programmable and are started on request. With the three timers, three message objects can be programmed, which will be sent without any software interaction. By shifting the NM supervision and the operation to send NM messages into the CAN module, less modules need to be active and the sleep time of the ECU is extended.

The mechanisms introduced into the Multi-CAN+ module, which is available in the Aurix family ▶

What savings can be achieved?

Based on uncertainties and the additional effort to implement the measures discussed, there must be a substantial impact on energy balance in order to force an introduction into a car architecture. Saving potential is strongly dependent on the question of how many nodes are suited to enter energy saving modes while the car is in operation. Deactivated engine control units or airbag systems are not usually an option. However deactivation of the electrical seat control while driving (beyond a certain vehicle speed for example) or a sleep mode for a door control unit (as the door functions are rarely used while driving) can be seriously considered.

The example of the door control unit shows the complexity of this topic. In case of an accident the door lock needs to be unlocked without a tangible delay; therefore a fast wake of a sleeping door module seems to be necessary. Furthermore, driver interaction has to be taken into account, for example opening the window or moving the seat while driving,

which requires a response without a noticeable delay for the customer.

The concepts of partial and pretended networking can co-exist in a car, so in the future both concepts can contribute to the total power saving. A sample calculation based on a typical electronics network of a mid-size car in the premium segment with 40 ECUs has been presented for the first time in 2010 [7], but has been a little updated (see Figure 11) in the meantime in order to show potential of co-existence of partial and pretended networking. This calculation covers average current consumption without consideration of external loads.

Even higher value savings have been reported. A German OEM has mentioned a target value of savings in the range of 2,6 g CO₂/km for introduction of partial networking into a new network architecture [1]. However in order to achieve such a high value, additional measures are necessary, such as the deactivation of entire sub-nets (LIN) or incorporation of deactivated peripheral functions into the calculation.

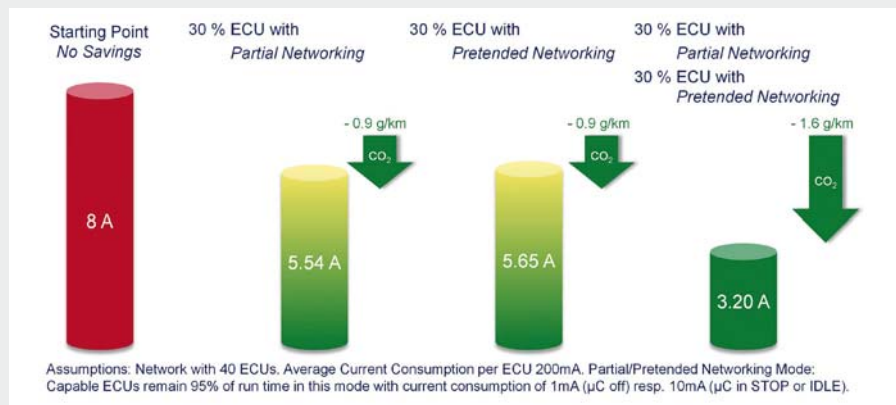


Figure 11: Sample savings calculation results

and the possibilities provided by ECU degradation and pretended networking, enable power savings for ECUs, which need to be partly awake for safety reasons or which cannot use partial networking because the wake-up time is far too long to be compliant to on-board diagnosis (OBD) regulations. As a result, a current car platform can be changed to consume less power without having to make changes to the car architecture.

Conclusions

A first implementation of partial networking has been announced for 2013/2014 [4], where the entire electronics network and hardware/software architecture will be adapted accordingly. Although the saving potential of pretended networking is smaller than partial networking, it is much easier to integrate into existing networks and can be used in ECUs, which need a very fast response at any time. One car manufacturer has announced an introduction scenario in a real car platform for 2015 onwards [5]. The Tier1 community still have concerns regarding the impact on reliability of given ECUs, and this needs to be seriously considered.

Taking a mid-term view, all the described energy saving methods will probably be implemented; parallel occurrence in one car architecture is possible. Partial networking requires special transceivers or SBCs (system basis chips), which have already been announced by several semiconductor vendors. Pretended networking can be used to start power saving right now, without changes to the network architecture, enabling power saving without any special hardware. All measures taken in new micro-controllers further increase the power saving potential. ◀

References (2)

- [7] Thomas Liebetrau
Wege zur Energieeinsparung im Fahrzeugnetzwerk – Teilnetzbetrieb und skalierbare Funktionalität
Elektronik automotive congress · Ludwigsburg · 2010
- [8] Thomas Liebetrau
Teilnetzbetrieb in komplexen Netzwerkarchitekturen – Migration in bestehende Netzwerke
Elektronik im Kraftfahrzeug, Günter Schmitz (Hrsg.) Haus der Technik, Fachbuch Band 123, Expert Verlag · ISBN 978-3-8169-3110-2
- [9] Monetti, Otter, Ulshöfer
Spritverbrauch senken und Reichweite erhöhen – System-Basis-Chip für den Teilnetzbetrieb am CAN-Bus
Elektronik Automotive · WEKA Fachmedien · November 2011
- [10] Infineon Introduces
Microcontroller Multicore Architecture for Automotive Applications
Infineon News Releases, October 2011

Pioneering new technologies
Pioneering new technologies



Sensor-Technik Wiedemann GmbH
Mobile Controllers and Measurement Technologies

Control units from the ESX®-family



ESX®-3XL



ESX®-10X



ESX®-TC3



ESX®

- freely programmable controllers (in C and IEC61131-3)
- applications in mobile work machines and commercial vehicles

ESX®-3XL

32bit-controller with 136 I/Os, Approved for safety related applications (SIL2, PLd)

ESX®-TC3

Teleservice module with GSM, GPRS, GPS, Wi-Fi, Bluetooth®, Ethernet and USB

ESX®-10X

CAN-Bus I/O-Modules

Pressure transmitter with thin-film measuring element



M01-CAN

- especially for applications in mobile machines and commercial vehicles
- highest media compatibility
- pressure ranges from 0 ... 25 bar to 0 ... 1000 bar (Overall accuracy in the temperature compensated range: 1%)
- max. media temperature 150°C / max. ambient temperature 125°C
- wetted parts and case in stainless-steel
- CAN-Bus interface

Exhibitions



SPS/IPC/DRIVES, Nuremberg
27. – 29.11.2012
Hall 7, Booth 7-169



bauma 2013, Munich
15. – 21.04.2013
Hall A5, Booth 119

Sensor-Technik Wiedemann GmbH
Am Bärenwald 6 · 87600 Kaufbeuren
Germany
Telephone +49 (0) 83 41-95 05-0

Understanding and using the CAN protocol

The book

Marco Di Natale,
Haibo Zeng,
Paolo Giusto,
Arkadeb Ghosal:
Understanding and Using the Controller Area Network Communication Protocol – Theory and Practice.
Springer Science + Business Media, 2012
(ISBN 978-1-4614-0314-2).

Link

www.springer.com

Contents

Chapter 1 contains a short summary of the CAN standard.
Chapter 2 describes hardware controllers and software layers in CAN communication architectures.
Chapter 3 focuses on the worst-case time analysis.
Chapter 4 and 5 present the stochastic and statistical timing analyses.
Chapter 6 addresses reliability issues.
Chapter 7 deals with the analysis of message traces.
Chapter 8 describes commercial tools, and chapter 9 contains a summary of higher-layer protocols.

Other books

The CAN Newsletter Online (www.can-newsletter.org) comprises a list of other English CAN books. For CAN books written in other languages you may contact CiA office (headquarters@can-cia.org).

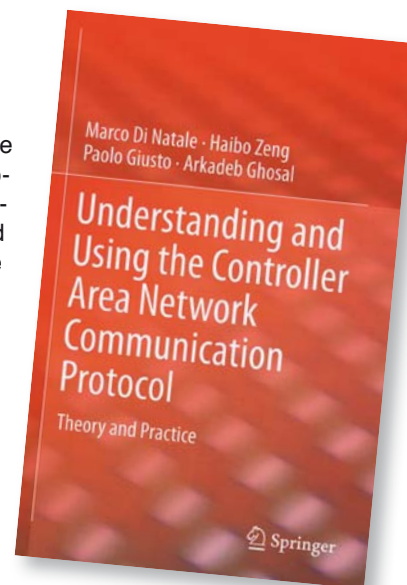
The first chapter of the 223-pages book describes several CAN physical layer options and the CAN data link layer protocol. The four authors combine theoretical background knowledge and practical experiences. Paolo Giusto works with General Motors (USA) and Arkadeb Ghosal is an employee of National Instruments (USA). Marco Di Natale from the Retis Laboratory (Italy) and Haibo Zeng from the McGill University (Canada) are responsible for the more theoretical content. After the brief introduction of the CAN basics, the following chapters focus on interaction layers, worst-case time, stochastic and statistical as well as reliability analysis. This is the first book that describes these topics in such details.

Of course, some of the details have been published in academic papers, but not combined in one publication. The hard-covered book is more than a collection of conference papers. It contains some practical hints and kinks as well.

The last chapter deals with some higher-layer protocols such as J1939, CANopen, CCP (CAN Calibration Protocol), and TTCAN. This part of the book provides just a very brief overview. A deeper understanding of them is unfortunately not provided. And there is no relation to the chapters before. An additional chapter describes “commercial tools for configuring, analyzing, and cali-

brating a CAN communication system”. The book also contains a list of symbols and a list of 65 references, which are followed by an index.

The most unique and interesting parts of the book are those, which analyze in depth the response times, the communication reliabil-



Chapter 6.7: Babbling idiot faults and bus guardians

“Besides physical failures, what is probably the most serious concern in a CAN network is the event of a node behaving as a babbling idiot. In this case, a node may (permanently or sporadically) erroneously transmit a message stream (possibly with a low identifier) with a higher rate than its design specification, or maybe simply produce messages earlier than expected. In this case, nothing prevents a (faulty) flow of high priority messages from disturbing the communication of other nodes, to the point of possibly bringing them to starvation. The standard CAN protocol has no solution to this problem, which needs of course an appropriate treatment in safety-critical systems. The solution should consist in the detection of nodes that are misbehaving and their isolation from the network. Of course, the detecting device must be external to the transmit-

ting node and capable of disconnecting it from the network. Such device is conventionally called a Bus guardian.

Bus guardians for CAN have been discussed and proposed in scientific literature, both as devices working in pair with the transmitting nodes, and as devices integrated in a start concentrator for star topologies. Commercial bus guardians are however not available today, quite possibly because the reliability of simple CAN networks has been in practice quite sufficient for handling today’s applications and the use of CAN for high-reliability, high-integrity systems is still not quite seen as a near-future option.”

(Reading probe from “Understanding and Using the CAN communication protocol” by Marco Di Natale, Haibo Zeng, Paolo Giusto, and Arkadeb Ghosal)

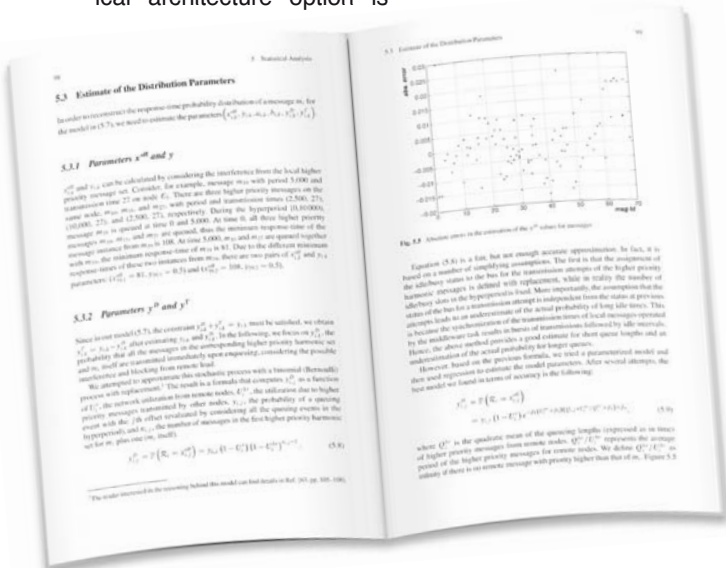
ity, and topics such as priority inversion, lost of messages, etc. The authors have long-time experiences in using CAN. You can see this already in the headline of the first chapter: "The CAN 2.0b Standard". This CAN protocol, introduced in 1993, is standardized in ISO 11898, and has been split in 2003 to ISO 11898-1 (data link layer) and ISO 11898-2 (high-speed physical layer). In the preface, they reference the ISO 11519-2 low-speed physical layer, which has been withdrawn about ten years ago. Also in other parts of the book, terminology is not always up-to-date or close to laboratory slang.

The more than 140 figures and the 35 tables are very helpful to understand some of the complex topics. In particular, the response-time analysis is sometimes very theoretical and hard to read without graphics and examples. Figures tell more than words. "After worst-case analysis and stochastic analysis, another alternative for the timing evaluation of CAN systems is the use of statistical analysis, possibly in conjunction with simulation, or leveraging data from traces and simulations." The authors present regression formulas to predict the probability of message latencies in a CAN system for which only limited information is available, "for example, when a hypothetical architecture option is

analyzed". This is not only interesting for automotive system designers but also for industrial and other CAN users. It would be interesting to extend those analyses specifically for higher-layer protocols such as CANopen.

The sixth chapter analyses in some details the reliability of CAN communication. The authors provide first some theoretical background information. Reliability is for them "the ability of a system to perform its specified function for a prescribed time under stipulated environment conditions". It is, "along with availability, safety, and other metrics, part of the more general concept of dependability". The authors discuss error rates in CAN, deviation points in the CAN protocol such as incorrect values in the data length code (DLC), fault confinement and transition of bus-off state, inconsistent omissions or duplicate messages, and protocol vulnerability. This book comes late, due to the fact that CAN technology has been introduced more than 25 years ago. Nevertheless, for newcomers it is very helpful, and even CAN experts may appreciate to dig deeper into the theoretical background and to get some practical hints – rules of thumb, so-to-say.

Holger Zeltwanger



LPC11C00 for elevator control systems

- ▶ High-performance 50 MHz ARM® Cortex™-M0 microcontroller
- ▶ CANopen drivers in ROM, firmware updates enabled via CAN
- ▶ Integrated CAN transceiver



Subscription

Please use the following classifications for filling in your subscription form:

A Position in company

- 0. Other position
- 1. Director
- 2. Technical manager
- 3. Marketing manager
- 4. Sales manager
- 5. System designer
- 6. Device designer
- 7. Purchasing manager

B. Company's CAN business

- 0. Other business
- 1. Semiconductor manufacturer
- 2. Device manufacturer
- 3. Software house
- 4. System integration
- 5. Service provider
- 6. End-user
- 7. Research

C. CAN application interest

- 1. Passenger cars
- 2. Heavy-duty vehicles
- 3. Rail vehicles
- 4. Maritime vehicles
- 5. Aircraft/Aerospace vehicles
- 6. Power generation systems
- 7. Factory automation systems
- 8. Process automation systems
- 9. Industrial machine control systems
- 10. Construction machine control systems
- 11. Embedded control systems
- 12. Building automation
- 13. Door control systems
- 14. Lift control systems
- 15. Medical devices and systems
- 16. Science and research systems

D. Company size

- 1. 1 - 9 employees
- 2. 10 - 49 employees
- 3. 50 - 99 employees
- 4. 100 - 999 employees
- 5. 1000 - 9999 employees
- 6. 10000 - 99999 employees
- 7. more than 100000 employees

CAN Newsletter

I hereby subscribe to the free-of-charge CAN Newsletter for the next four editions (published in March, June, September, and December of every year).

Print version PDF version

Company

Name

Address

City, ZIP

Phone (Country code - Area code - Number)

Fax (Country code - Area code - Number)

E-mail

URL

Position (see A)

Application (see C)

Business (see B)

Size (see D)

I like to receive CiA's Weekly Telegraph

Please send your subscription form to CAN in Automation (CiA) GmbH, Kontumazgarten 3, DE-90429 Nuremberg, Germany, or fax it to +49-911-928819-79 or e-mail it to headquarters@can-cia.org. You may also subscribe online at www.can-cia.org.

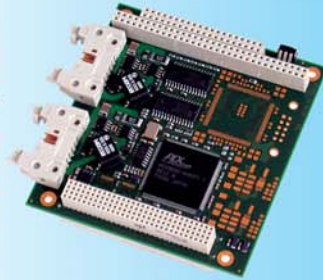
PCIexpress



CAN-PCIe/200

- PCI Express-CAN Interface
- Passive board for one or optional two interfaces
- Data transfer rates up to 1 Mbit/s
- Electrically isolated

PCI104/plus



CAN-PCI104/200

- PCI104+-CAN Interface
- One or two independent CAN interfaces for PCI104 bus
- Data transfer rates up to 1 Mbit/s
- Electrically isolated
- DeviceNet option available

PCI



CAN-PCI/405-4

- 4 high performance CAN interfaces
- local intelligence based on PowerPC
- Data transfer rates up to 1 Mbit/s
- Electrically isolated
- Provides high resolution hardware timestamps

Ethernet



EtherCAN

- 10/100 BaseT ETHERNET-CAN Gateway
- ETHERNET protocols: TCP/IP, Modbus/TCP
- Data transfer rates up to 1 Mbit/s
- Configuration by WEB browser
- CANopen master firmware

USB 2.0



CAN-USB/2

- CAN-USB 2.0 Interface
- Intelligent CAN interface with ARM 7
- USB 2.0 high speed interface with data rates of 480 Mbit/s
- Data transfer rates up to 1 Mbit/s
- Electrically isolated
- Provides high resolution hardware timestamps

Gateways



CAN-CBX

- CANopen Input/Output Modules with In-Rail-Bus
- Connection of CAN and supply voltage without wiring effort
- Data transfer rates up to 1 Mbit/s
- Electrically isolated

Gateways

- PROFINET-CAN
- PROFIBUS-CAN
- PROFIBUS-DeviceNet
- EtherNet/S7-CAN

Operating Systems

esd supports the real-time multitasking operating systems VxWorks, QNX, LynxOS, RTX, OS9, RT-Linux and RTOS-UH as well as various UNIX (Linux) and Windows (VISTA/XP/CE/2000/9x) systems.

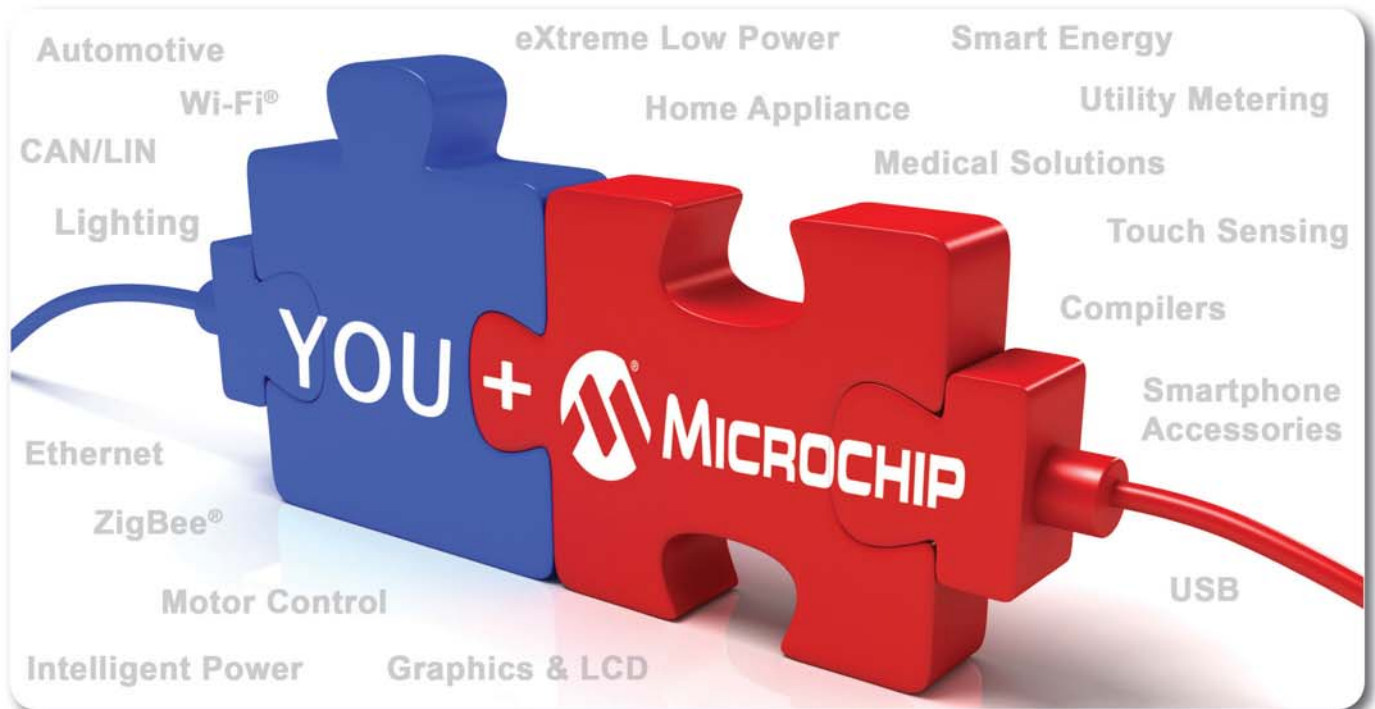
CAN Tools

- CANreal: Display and recording of CAN message frames
- CANplot: Display of online/offline CAN data
- CANrepro: Replay of pre-recorded CAN message frames via esd CAN interface
- CANscript: Python scripting tool to handle CAN messages
- COBview: Effective CANopen tool for the analysis/diagnostics of CANopen nodes

the tools are free of charge on the driver CD or to be downloaded here: www.esd-electronics.com/tools



A Perfect Fit For Your Embedded Design...



The most popular choice of embedded designers.

Choosing an embedded semiconductor is much more than just picking a product. Over 70,000 companies, from the largest global enterprises to innovative start-ups, choose Microchip because:

Microchip Understands Commercial Pressures

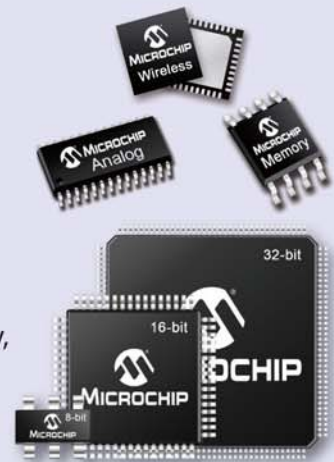
We have some of the best stock availability, the shortest leadtimes, an extensive range of channel partners and sell direct to any customer through our website.

Microchip Offers Solutions for Today's Most Challenging Applications

Our product range encompasses an industry leading portfolio of 8-, 16-, and 32-bit microcontrollers, analog, memory, power management and wireless, as well as microcontrollers to meet the demands of applications, from touch sensing and driving displays to industrial control.

Microchip Makes It Easy for Your Development Teams to Succeed

With hundreds of software tools and development boards, 35 regional training centres across the world and technical support available 24 hours a day, we help customers overcome challenges and bring products to market.



For more information, go to: www.microchip.com



Microcontrollers • Digital Signal Controllers • Analog • Memory • Wireless